



TRUE FOOD SERVICE EQUIPMENT, INC.

2001 East Terra Lane • O'Fallon, Missouri 63366-4434 • (636)240-2400
 Fax (636)272-2408 • Toll Free (800)325-6152 • Intl Fax# (001)636-272-7546
 Parts Dept. (800)424-TRUE • Parts Dept. Fax# (636)272-9471 • www.truemfg.com

Project Name: _____

Location: _____

Item #: _____ Qty: _____

Model #: _____

A/A #

S/S #

Model:
TFP-72-30M-D-4

Food Prep Table:
Door and Drawered Food Prep Unit



TFP-72-30M-D-4

- ▶ True's food prep units are designed with enduring quality that protects your long term investment.
- ▶ Energy saving, environmentally friendly (134A), exclusive forced-air refrigeration system holds 33°F to 41°F (.5°C to 5°C).
- ▶ All stainless steel front, top and ends. Matching aluminum finished back.
- ▶ Door fitted with 12" (305 mm) long recessed handle that is foamed-in-place with a sheet metal interlock to ensure permanent attachment.
- ▶ Stainless steel, patented, foam insulated lid and hood keep pan temperatures colder, lock in freshness and minimize condensation. Removable for easy cleaning.
- ▶ Interior - attractive, NSF approved, clear coated aluminum liner. Stainless steel floor with coved corners.
- ▶ 8" (204 mm) deep, ½" (13 mm) thick, full length removable cutting board included. Sanitary, high density, NSF approved white polyethylene provides tough preparation surface.
- ▶ Each drawer accommodates one (1) full size 12"L x 20"W x 6"D (305 mm x 508 mm x 153 mm) food pan & three (3) ½ size or six (6) ¼ size & three (3) ⅓ size pans per drawer (sold separately). Drawer will support varying size pan configurations with available pan divider bars (drawer pans sold separately).
- ▶ Foamed-in-place using a high density, polyurethane insulation that has zero ozone depletion potential (ODP) and zero global warming potential (GWP).

Door or drawer assemblies can be located in any section of the cabinet. Location of door/drawers must be indicated at time of ordering.

ROUGH-IN DATA

Specifications subject to change without notice.
 Chart dimensions rounded up to the nearest ⅛" (millimeters rounded up to next whole number).

Model	Doors	Drawers	Shelves	Pans (top)	Cabinet Dimensions (inches) (mm)			HP	Voltage	Amps	NEMA Config.	Cord Length (total ft.) (total m)	Crated Weight (lbs.) (kg)
					L	D†	H*						
TFP-72-30M-D-4	1	4	2	30	72⅞ 1832	31½ 801	45¾ 1162	⅓ N/A	115/60/1	5.1 N/A	5-15P	7 2.13	635 288

† Depth does not include 2" (51 mm) for cutting board.
 * Height does not include ¾" (19 mm) for castors.

	APPROVALS: 	AVAILABLE AT:
4/16	Printed in U.S.A.	

Model:
TFP-72-30M-D-4

Food Prep Table: Door and Drawered Food Prep Unit



STANDARD FEATURES

DESIGN

- True's commitment to using the highest quality materials and oversized refrigeration systems provides the user with colder product temperatures, lower utility costs, exceptional food safety and the best value in today's food service marketplace.

REFRIGERATION SYSTEM

- Factory engineered, self-contained, capillary tube system using environmentally friendly (CFC free) 134A refrigerant.
- Energy saving, factory balanced refrigeration system with guided airflow to provide uniform temperature in food pans and cabinet interior.
- Exclusive forced-air design holds 33°F to 41°F (5°C to 5°C) product temperature in food pans and cabinet interior. Complies with and listed under ANSI/NSF-7.
- High efficiency evaporator fan motor and larger fan blades give True Food Prep units a more efficient, low velocity, high volume airflow design.
- Easy access to all condensing unit components from back of cabinet.

CABINET CONSTRUCTION

- Exterior - stainless steel front, top and ends. Matching aluminum finished back.
- Interior - attractive, NSF approved, clear coated aluminum liner. Stainless steel floor with coved corners.
- Insulation - entire cabinet structure and drawer facings are foamed-in-place using a high density, polyurethane insulation that has zero ozone depletion potential (ODP) and zero global warming potential (GWP).

- 2 1/2" (64 mm) diameter castors - locks provided on front set.
- Solid State Electronic Control, accessible on back of the unit.

DOOR/DRAWERS

- Door or drawer assemblies can be located in any section of the cabinet. Location of door/drawers must be indicated at time of ordering.
- Door- Stainless steel exterior with clear aluminum liner to match cabinet interior.
- Drawers- Stainless steel exterior drawer facings and liners. Stainless steel drawer frames.
- Door fitted with 12" (305 mm) long recessed handle that is foamed-in-place with a sheet metal interlock to ensure permanent attachment.
- Each drawer fitted with 12" (305 mm) long recessed handle that is foamed-in-place with a sheet metal interlock to ensure permanent attachment.
- Magnetic drawer gaskets of one piece construction, removable without tools for ease of cleaning.
- Heavy-duty stainless steel drawer slides and rollers. Removable without tools for easy cleaning.
- Each drawer accommodates one (1) full size 12"L x 20"W x 6"D (305 mm x 508 mm x 153 mm) food pan & three (3) 1/2 size or six (6) 1/3 size & three (3) 1/4 size pans per drawer (sold separately). Drawer will support varying size pan configurations with available pan divider bars (drawer pans sold separately).

MODEL FEATURES

- Evaporator is epoxy coated to eliminate the potential of corrosion.
- 8" (204 mm) deep, full length removable cutting board. Sanitary, high-density, NSF approved white polyethylene provides tough preparation surface.
- Stainless steel, patented, foam insulated lid and hood keep pan temperatures colder, lock in freshness and minimize condensation. Removable for easy cleaning.
- Comes standard with 30 (1/8 size) 6 7/8" L x 6 1/4" W x 4" D (175 mm x 159 mm x 102 mm) clear polycarbonate, NSF approved, food pans in countertop prep area.
- Countertop pan opening designed to fit varying size pan configurations with available pan divider bars. Varying size pans supplied by others.
- NSF-7 compliant for open food product.

ELECTRICAL

- Unit completely pre-wired at factory and ready for final connection to a 115/60/1 phase, 15 amp dedicated outlet. Cord and plug set included.



115/60/1
NEMA-5-15R

OPTIONAL FEATURES/ACCESSORIES

Upcharge and lead times may apply.

- Pan dividers
- Single overshelf
- Double overshelf

PLAN VIEW

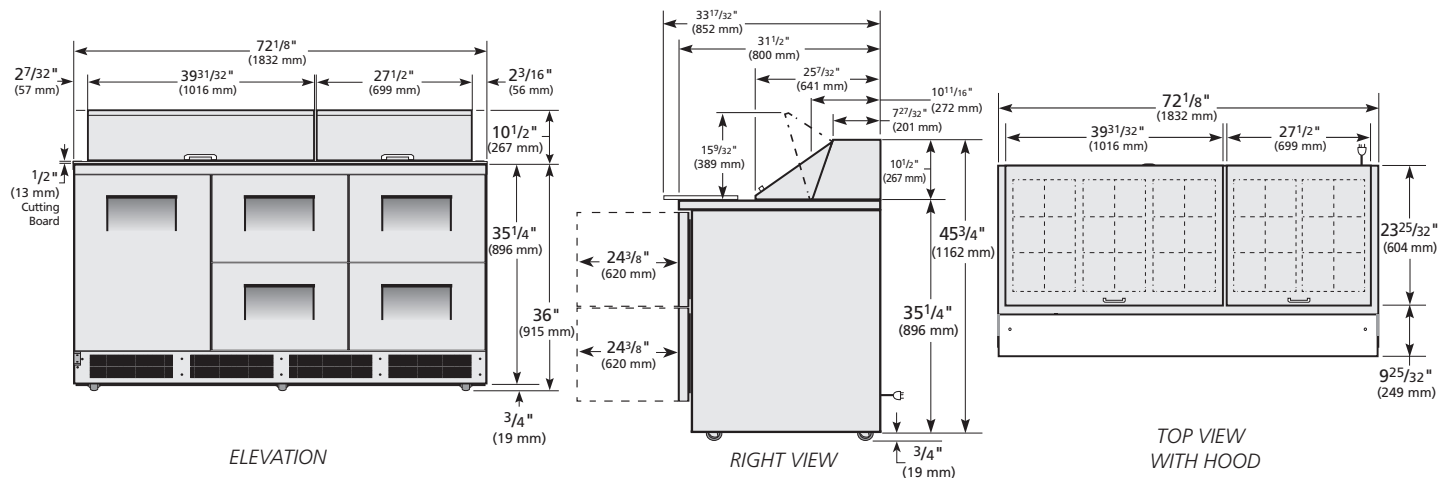

WARRANTY*
Three year warranty on all parts and labor and an additional 2 year warranty on compressor. (U.S.A. only)

METRIC DIMENSIONS ROUNDED UP TO THE NEAREST WHOLE MILLIMETER

SPECIFICATIONS SUBJECT TO CHANGE WITHOUT NOTICE



Model	Elevation	Right	Plan	3D	Back
TFP-72-30M-D-4					

*RESIDENTIAL APPLICATIONS: TRUE assumes no liability for parts or labor coverage for component failure or other damages resulting from installation in non-commercial or residential applications.

TRUE FOOD SERVICE EQUIPMENT