



**TRUE FOOD SERVICE  
EQUIPMENT, INC.**

2001 East Terra Lane • O'Fallon, Missouri 63366-4434 • (636)240-2400  
 Fax (636)272-2408 • Toll Free (800)325-6152 • Intl Fax# (001)636-272-7546  
 Parts Dept. (800)424-TRUE • Parts Dept. Fax# (636)272-9471 • www.truemfg.com

Project Name: \_\_\_\_\_

Location: \_\_\_\_\_

Item #: \_\_\_\_\_ Qty: \_\_\_\_\_

Model #: \_\_\_\_\_

A/A #

SIS #

Model:  
**THAC-36**

**THAC Series:**  
*Horizontal Air Curtain Refrigerated Merchandiser*



**THAC-36**

- ▶ True's air curtain merchandisers are designed with enduring quality that protects your long term investment.
- ▶ True's commitment to using the highest quality materials and oversized refrigeration systems provides the user with colder product temperatures and lower utility costs in a convenient spot merchandiser for packaged food and beverage.
- ▶ Uniquely sized for placement in a variety of popular impulse merchandising locations.
- ▶ Oversized, factory balanced, refrigeration system holds 35°F to 40°F (1.6°C to 4.4°C).
- ▶ Exclusive reversing condenser fan motor. Fan motor reverses during defrost off cycles to help keep condenser coil free from dirt, dust and debris. Keeping coils clean optimizes the unit's performance providing colder holding temperatures and increased energy efficiency. Regularly scheduled thorough cleaning of coils still recommended.
- ▶ Exterior - non-peel or chip white powder coated steel; durable and permanent.
- ▶ Interior - attractive, NSF approved, white aluminum interior liner with stainless steel floor.
- ▶ Air curtain top provides fast, easy access to product while maximizing attention to merchandising.
- ▶ Entire cabinet structure is foamed-in-place using Ecomate. A high density, polyurethane insulation that has zero ozone depletion potential (ODP) and zero global warming potential (GWP).

**ROUGH-IN DATA**

Specifications subject to change without notice.  
 Chart dimensions rounded up to the nearest 1/8" (millimeters rounded up to next whole number).

Model	Shelves	Cabinet Dimensions (inches) (mm)			HP	Voltage	Amps	NEMA Config.	Cord Length (total ft.) (total m)	Crated Weight (lbs.) (kg)
		L	D	H						
THAC-36	3	36 1/8 918	30 1/8 766	43 3/8 1102	3/8 N/A	115/60/1	9.4 N/A	5-15P	6.5 1.98	330 150



APPROVALS:

AVAILABLE AT:

Model:  
**THAC-36**

**THAC Series:**  
*Horizontal Air Curtain Refrigerated Merchandiser*



**STANDARD FEATURES**

**DESIGN**

- Designed using the highest quality materials and components to provide the user with colder product temperatures and lower utility costs in an attractive merchandiser that brilliantly displays package food and beverage.

**REFRIGERATION SYSTEM**

- Factory engineered, self-contained, capillary tube system using environmentally friendly (CFC free) 134A refrigerant.
- Time initiated, time terminated off cycle defrost system
- Extra large evaporator coil balanced with higher horsepower compressor and large condenser; maintains cabinet temperatures of 35°F to 40°F (1.6°C to 4.4°C).
- Sealed, cast iron, self-lubricated evaporator fan motor(s) and larger fan blades give True merchandisers a more efficient, low velocity, high volume airflow design, colder holding temperatures and faster recovery in high use situations.
- Condensing unit accessed from front of cabinet, slides out for easy maintenance.

- Exclusive reversing condenser fan motor. Fan motor reverses during defrost off cycles to help keep condenser coil free from dirt, dust and debris. Keeping coils clean optimizes the unit's performance providing colder holding temperatures and increased energy efficiency. Regularly scheduled thorough cleaning of coils still recommended.

**CABINET CONSTRUCTION**

- Exterior - non-peel or chip white powder coated steel; durable and permanent.
- Interior - attractive, NSF approved, white aluminum liner with stainless steel floor.
- Cabinet fitted with leg levelers.
- Insulation - entire cabinet structure is foamed-in-place using Ecomate. A high density, polyurethane insulation that has zero ozone depletion potential (ODP) and zero global warming potential (GWP).

**SHELVING**

- Three (3) level tiered stainless steel floor.

**LIGHTING**

- Fluorescent interior lighting, safety shielded.
- Cabinet lighting utilizes electronic ballast and T-8 bulbs for brighter illumination, longer bulb life and increased energy efficiency.

**MODEL FEATURES**

- Listed under NSF-7 for the storage and/or display of packaged and bottled product.

**ELECTRICAL**

- Unit completely pre-wired at factory and ready for final connection to a 115/60/1 phase - 15 amp dedicated outlet. Cord and plug set included.



115/60/1  
NEMA-5-15R

**RECOMMENDED OPERATION CONDITIONS**

- Designed to operate in an environment where temperatures and humidity do not exceed 75°F (24°C) and 55% relative humidity
- Unit should not be installed near HVAC vents, fans on doorways that will disrupt the air curtain and compromise the function of the cabinet. Unit should not be installed in direct sunlight.
- Model will run most efficiently when completely loaded with product.
- Drain plumbing hookup recommended.

**OPTIONAL FEATURES/ACCESSORIES**

Upcharge and lead times may apply.

- Black exterior.
- Stainless exterior.
- 2" (51 mm) diameter castors
- Bumper guards.
- Night cover.
- Pressure safety control.

**PLAN VIEW**

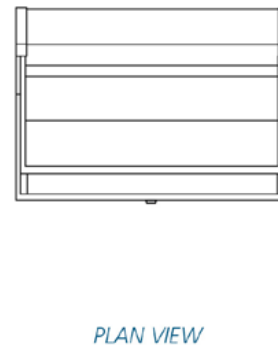
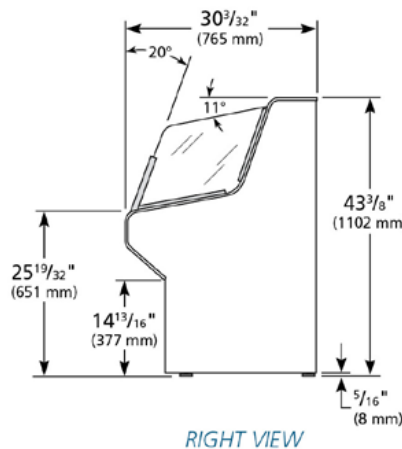
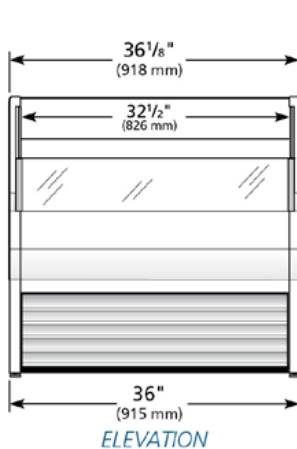

**WARRANTY\***  
Three year warranty on all parts and labor and an additional 2 year warranty on compressor. (U.S.A. only)

METRIC DIMENSIONS ROUNDED UP TO THE NEAREST WHOLE MILLIMETER

SPECIFICATIONS SUBJECT TO CHANGE WITHOUT NOTICE



Model	Elevation	Right	Plan	3D	Back
THAC-36					

\*RESIDENTIAL APPLICATIONS: TRUE assumes no liability for parts or labor coverage for component failure or other damages resulting from installation in non-commercial or residential applications.

**TRUE FOOD SERVICE EQUIPMENT**