



TRUE FOOD SERVICE EQUIPMENT, INC.

2001 East Terra Lane • O'Fallon, Missouri 63366-4434 • (636)240-2400
 Fax (636)272-2408 • Toll Free (800)325-6152 • Intl Fax# (001)636-272-7546
 Parts Dept. (800)424-TRUE • Parts Dept. Fax# (636)272-9471 • www.truemfg.com

Project Name: _____

Location: _____

Item #: _____ Qty: _____

Model #: _____

A/A #

S/S #

Model:
TUC-60F-LP-HC

Undercounter:

Low Profile Solid Door Freezer with Hydrocarbon Refrigerant

TUC-60F-LP-HC



- ▶ True's undercounter's are designed with enduring quality and value that protects your long term investment. Our commitment to using the highest quality materials and oversized refrigeration ensures exceptional food preservation.
- ▶ "Low Profile" models are designed to slide easily under custom built countertops.
- ▶ Factory engineered, self-contained, capillary tube system using environmentally friendly R290 hydro carbon refrigerant that has zero (0) ozone depletion potential (ODP), & three (3) global warming potential (GWP).
- ▶ High capacity, factory balanced refrigeration system holds -10°F (-23.3°C). Ideally suited for both frozen foods and ice cream.
- ▶ All stainless steel front, top and ends. Corrosion resistant GalFan coated steel back.
- ▶ Interior - attractive, NSF approved, clear coated aluminum liner with stainless steel floor.
- ▶ Self closing doors. Positive seal, torsion type closure system.
- ▶ Foamed-in-place using a high density, polyurethane insulation that has zero ozone depletion potential (ODP) and zero global warming potential (GWP).

ADA & Low Profile Comparison



1 1/2" diameter dual swivel castors for "LP" models.

ROUGH-IN DATA

Specifications subject to change without notice. Chart dimensions rounded up to the nearest 1/8" (millimeters rounded up to next whole number).

Model	Doors	Shelves	Cabinet Dimensions (inches) (mm)			HP	Voltage	Amps	NEMA Config.	Cord Length (total ft.) (total m)	Crated Weight (lbs.) (kg)
			W	D†	H*						
TUC-60F-LP-HC	2	4	60 3/8 1534	30 1/8 766	29 3/4 756	1/2 N/A	115/60/1	4.8 N/A	5-15P	7 2.13	340 155

† Depth does not include 1" (26 mm) for rear bumpers.

* Height does not include 2 1/2" (54 mm) for castors.

4/17 Printed in U.S.A.

APPROVALS:

AVAILABLE AT:

Model:
TUC-60F-LP-HC

Undercounter:
*Low Profile Solid Door Freezer with
Hydrocarbon Refrigerant*



STANDARD FEATURES

DESIGN

- True's commitment to using the highest quality materials and oversized refrigeration systems provides the user with colder product temperatures, lower utility costs, exceptional food safety and the best value in today's food service marketplace.
- "Low Profile" models are designed to slide easily under custom built countertops.

REFRIGERATION SYSTEM

- Factory engineered, self-contained, capillary tube system using environmentally friendly R290 hydrocarbon refrigerant that has zero (0) ozone depletion potential (ODP), & three (3) global warming potential (GWP).
- Energy efficient, factory balanced refrigeration system with guided airflow to provide uniform product temperatures.
- High capacity, factory balanced refrigeration system that maintains -10°F (-23.3°C) temperatures. Ideal for both frozen foods and ice cream.
- State of the art, electronically commutated evaporator and condenser fan motors. ECM motors operate at higher peak efficiencies and move a more consistent volume of air which produces less heat, reduces energy consumption and provides greater motor reliability.
- Condensing unit access located in back, slides out for easy maintenance.
- Automatic defrost system time-initiated, time-terminated.

CABINET CONSTRUCTION

- Exterior - stainless steel front, top and ends. Corrosion resistant GalFan coated steel back.

- Interior - attractive, NSF approved, clear coated aluminum liner. Stainless steel floor with coved corners.
- Insulation - entire cabinet structure and solid doors are foamed-in-place using a high density, polyurethane insulation that has zero ozone depletion potential (ODP) and zero global warming potential (GWP).
- 1 1/2" (39 mm) diameter dual swivel castors permits easy placement. 31 7/8" (810 mm) work surface height.

DOORS

- Stainless steel exterior with clear coated aluminum liner to match cabinet interior.
- door lock standard.
- Lifetime guaranteed heavy duty all metal working spec door handles.
- Positive seal self-closing doors with 90°(stay open feature. Doors swing within cabinet dimensions.
- Magnetic door gaskets of one piece construction, removable without tools for ease of cleaning.

SHELVING

- Four (4) adjustable, heavy duty PVC coated wire shelves. Two (2) top shelves - 27 9/16" L x 19 5/8" D (700 mm x 499 mm). Two (2) bottom shelves - 27 1/2" L x 13 3/8" D (699 mm x 340 mm). Four (4) chrome plated shelf clips included per shelf.
- Shelf support pilasters made of same material as cabinet interior; shelves are adjustable on 1/2" (13 mm) increments.

MODEL FEATURES

- Evaporator is epoxy coated to eliminate the potential of corrosion.
- Heavy duty 16 gauge top and 20 gauge doors.
- Counter-Top front is flush with front of doors.

- Exterior digital temperature display.
- Spec Series® logo.
- NSF/ANSI Standard 7 compliant for open food product.

ELECTRICAL

- Unit completely pre-wired at factory and ready for final connection to a 115/60/1 phase, 15 amp dedicated outlet. Cord and plug set included.



OPTIONAL FEATURES/ACCESSORIES

Upcharge and lead times may apply.

- Barrel locks (factory installed). Requires one per door.
- Basic overshelf.
- Sandwich/salad service shelf.
- Single utility shelf.
- Double utility shelf.
- Additional shelves.
- 30" (762 mm) deep, 1/2" thick, white polyethylene cutting board. Requires "L" brackets.
- 30" (762 mm) deep, 1/2" thick, composite cutting board. Requires "L" brackets.
- Heavy duty 16 gauge tops.
- Exterior rectangular digital thermometer (factory installed).
- Standard height units with 5" (127 mm) diameter castors. 36" (915 mm) work surface height.
- ADA compliant models with 34" (864 mm) work surface height.

PLAN VIEW

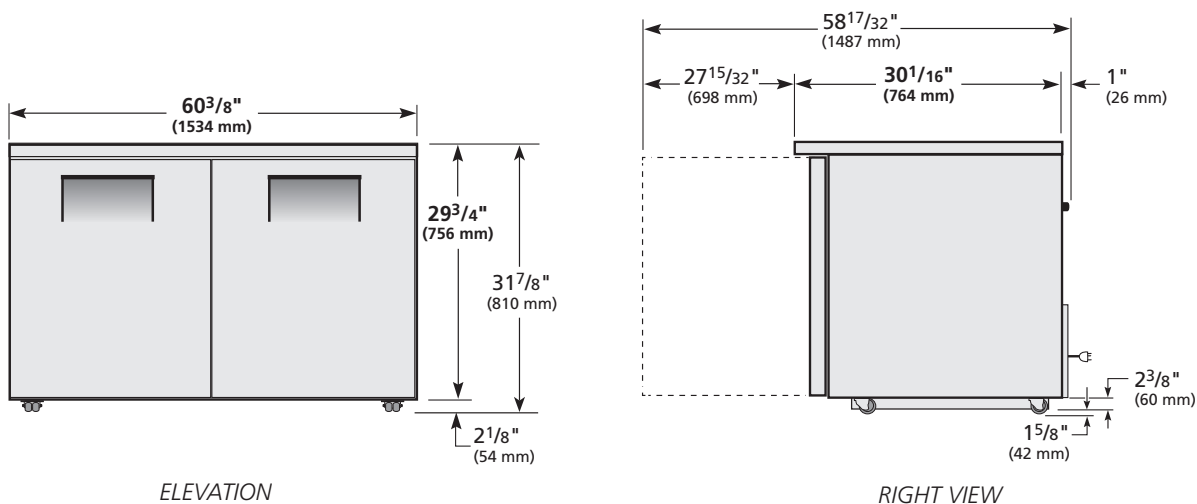

WARRANTY*
 Three year warranty on all parts and labor and an additional 2 year warranty on compressor.
 (U.S.A. only)

METRIC DIMENSIONS ROUNDED UP TO THE NEAREST WHOLE MILLIMETER
 SPECIFICATIONS SUBJECT TO CHANGE WITHOUT NOTICE



Model	Elevation	Right	Plan	3D	Back
TUC-60F-LP-HC					

*RESIDENTIAL APPLICATIONS: True assumes no liability for parts or labor coverage for component failure, factory defect or any other damages for units installed in non-commercial foodservice or residential applications.

TRUE FOOD SERVICE EQUIPMENT