

REFRIGERATOR MANUFACTURER
Turbo air
 more durable, efficient, beautiful

4184 E. Conant St.
 Long Beach, CA 90808
 Tel. 310-900-1000
 Fax. 310-900-1077
www.turboairinc.com

Project :	
Model # :	
Item # :	Qty :
Available W/H :	
Approval :	

Pass Thru Half Solid Door Ref. *Reach-In Top Mount PRO Series*

FEATURES & BENEFITS

**Model : PRO-26-2R-PT-N
 PRO-26-2R-PT-N-L**

■ **Self-Cleaning Condenser**

The accumulation of dust in the condenser can cause the failure or breakdown of refrigerators. Refrigerators run normally until they reach a certain level of accumulation. At some point, when they are over the limit, their performance drops quickly resulting in damage to, or disposal of the stored products inside. The Self-Cleaning Condenser device keeps the condenser clean and prevents system failure by automatically brushing daily.

■ **Digital temperature control & monitor system**

- Keep food products safe by maintaining constant temperatures.
- Alarms that sound when doors are not sealed shut; protect against food spoilage that originates from cold air leaks.
- Early warning alarm program detects issues before malfunction occurs.
- Digital display allows for easy monitoring.
- Programs interpret the condition of refrigeration systems by self-diagnosis.
- Rapid cool-down function (Turbo cooling).
- Automatic evaporator fan motor delays.

■ **Hydrocarbon refrigerants (R-290)**

With innovative and eco-friendly technology, Turbo Air brings you hydrocarbon refrigerators designed to meet DOE's Energy Conservation Standards in 2017 and to use EPA's SNAP Program approved HC refrigerants. Hydrocarbon refrigerants do not deplete the ozone layer and have very low contribution to global warming (ODP-0, GWP-3).

■ **Cold air distribution system**

Provides uniformly maintained temperature within the food zone.

■ **Hot gas condensate system**

Through Turbo Air's creative innovation, the condensate system surfaces have been specially treated to resist corrosion. This not only increases efficiency without the risk of refrigerant leakage from corrosion, but also prevents the overflow of condensate water.

■ **All stainless steel cabinet construction**

The PRO series model boasts a stainless steel interior and a 22 gauge stainless steel exterior (galvanized steel top, bottom). It guarantees the utmost in cleanliness and long product life. The PRO series model adds a touch of style to the most refined setting.

■ **Sturdy, clean stainless steel shelving**

Shelves are the most important part of cleanliness as they come in direct contact with food. After a while, PVC coated wire shelves may peel, rust and lead to unsanitary conditions. Only the Turbo Air PRO series uniquely provides stainless steel shelving.

■ **LED interior lighting**

■ **High-density polyurethane insulation**

The entire cabinet structure and solid doors are foamed-in-place using high density, CFC free polyurethane insulation.

■ **Thermostatic expansion valve**

■ **Top mount compressor**



Patented Self-Cleaning Condenser

This product is equipped with a fine mesh filter to the front of the condenser to catch dust, and a rotating brush that moves up and down daily to remove excess buildup outward and away.

■ **Refrigerator holds 33°F ~ 38°F for the best in food preservation**

■ **Lifetime guaranteed heavy duty hinges and handles**

■ **Built to maintain NSF standard temperatures in 100°F ambient**

- PRO-26-2R-PT-N: Right hinged
- PRO-26-2R-PT-N-L: Left hinged



Model	Swing Door	CU./FT.	#of Shelves	HP	AMPS	Crated Weight (lbs.)	L x D x H † (inches)
PRO-26-2R-PT-N(-L)	4	26.27	3	1/2	7.0	406	28 3/4 x 36 1/4 x 78

Model : PRO-26-2R-PT-N, PRO-26-2R-PT-N-L

ELECTRICAL DATA	
Voltage	115/60/1
Plug Type	Ⓢ NEMA 5-15P
Full Load Amperes	7.0
Compressor HP	1/2
Feed Wires with Ground	3
Cord Length (ft.)	9
Refrigerant	R-290
DIMENSIONAL DATA	
# of Doors	4
# of Racks Accepted	1
Net Capacity (cu. ft.)	26.27
Ext. Length Overall (in.)	28 ³ / ₄ (730mm)
Ext. Depth Overall (in.)*	36 ¹ / ₄ (920mm)
Ext. Height Overall (in.)†	78 (1982mm)
Int. Length Overall (in.)	23 ⁷ / ₈ (605mm)
Int. Depth Overall (in.)	27 ⁵ / ₈ (702mm)
Int. Height Overall (in.)	58 ³ / ₄ (1493mm)
# of Shelves	3
Shelf Size (L x D) (in.)	23 ¹ / ₂ x 26 ³ / ₈
Net Weight (lbs.)	355
Gross Weight (lbs.)	406

Design and specifications subject to change without notice.
Actual shipping weight may differ due to extra packing materials for product protection.
* Depth does not include 2-1/2" for door handles.
† Height does not include 5" for caster height.

■ **WARRANTY : 3 Year Parts and Labor Warranty**
Additional 2 Year Warranty on Compressor

■ **STANDARD FEATURES**

- Anti-corrosion coated evaporator
- Door locks standard
- Self-contained system
- Standard 4" dia. swivel casters with locks on the front set
- Easy replaceable one piece magnetic door gaskets
- Solid and sturdy grille design

■ **OPTIONAL ACCESSORIES**

- 5" caster, 1/2" diameter & 13 TPI:
M726500100 (non-brake), M726500200 (w/ brake)
- 4.7" leveling seismic leg (1/2", 13 TPI): 30221M0500
- 6" stainless steel leg: 30221M0600
- Additional stainless steel shelf: H26R901680
- Half door bun tray rack: TSP-2224
(each holds up to six 18"L x 26"D sheet pans-sold separately)
- Tray slides kits: TS1-N1(#1), TS1-N4(#4), TS1-UN(Universal)

PLAN VIEW

(unit : inch)

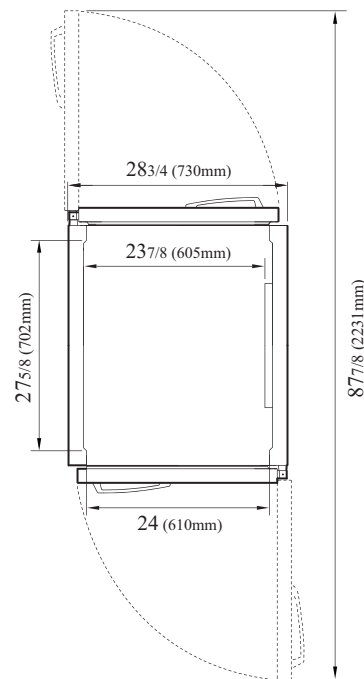

TOP VIEW

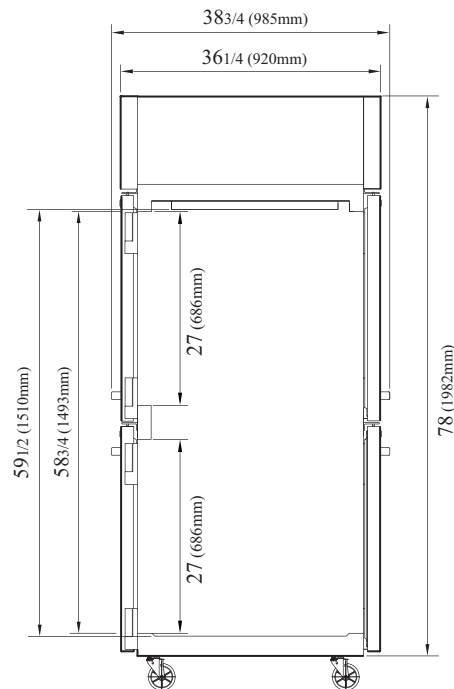

SIDE VIEW

Ver.20191118



- Turbo Air : 800-627-0032
- GK : 800-500-3519
- Warranty : 800-381-7770
- AC : 888-900-1002

