

## CHEF BASE REFRIGERATOR

CBR84-1

- Equipped with Secure-Temp 1.0™ Technology™
- 3 Year Parts & Labor Warranty Plus an Additional 2 Year Compressor Warranty
- Exclusive 2 Year Warranty on Santoprene Door Gaskets

**VICTORY ULTRASPEC™**  
FEATURING: **SecureTemp™**  
1.0

Secure-Temp 1.0™ is the industry's first and only full service temperature monitoring solution for your kitchen. Secure-Temp 1.0™ is standard on all Victory models and is HACCP compliant & meets NAFEM's data protocol.

**There are NO software or monthly monitoring fees.**  
Optional add on kits are available for additional units.

### STANDARD FEATURES

- Secure-Temp 1.0™ Technology
- Full Electronic Control
- Heavy Duty, Fire-Proof, Reinforced Insulated 16 Gauge Top  
*No heat shield required*
- Expansion Valve Technology
- 100% Front Breathing
- Marine Edge Standard
- **Lifetime Warranty On All Drawers & Slides**
- 12 Gauge Drawer Slides With 3 Stainless Steel Ball Bearings Per Each Drawer Slide
- Santoprene Door Gaskets with Exclusive 2 Year Warranty
- Stainless Steel Exterior & Aluminum Interior
- 6" Casters, 2 with Brakes Standard
- Upper Drawers Accommodate two 6" deep 12" x 20" pans  
*Food service pans not included*
- Lower Drawers Accommodate two 4" deep 12" x 20" pans  
*Food service pans not included*



**CBR84-1**

### OPTIONS & ACCESSORIES

- Flat Top
- Gasket Guards
- 3" Casters or 6" Seismic Legs
- Optional Voltages: 220/50/1, 220/60/1



**CABINET CONSTRUCTION**

Heavy-duty construction with stainless steel on top, front, sides, rear and drip guard top. Interior of cabinet is constructed of corrosion-resistant aluminum. Drawers are equipped with heavy-duty workflow handle. Cabinet integrity is reinforced by use of structural columns. Cabinets are insulated with foamed-in-place polyurethane insulation of 2" thickness for added strength and maximum energy efficiency.

**DRAWER CONSTRUCTION**

Drawer frames are constructed of heavy duty stainless steel and are supported on stainless steel telescoping drawer slides with three stainless steel roller bearing wheels for maximum support of stored food product. Upper pull-out drawers accommodate two 6" deep 12" x 20" pans of combinations of 1/6 size pans or larger. Lower pull-out drawers accommodate two 4" deep 12" x 20" pans or combinations of 1/6 size pans or larger. Heavy duty pan divider supports are supplied. Foodservice pans are not included. A snap in type vinyl magnetic gasket is attached to each drawer for positive seal.

**REFRIGERATION SYSTEM**

Self-contained refrigeration system utilizes R134a refrigerant metered by expansion valve. Automatic (hot gas) condensate evaporation is provided. Interior forced air system, with high humidity evaporator coils, provide the ideal environment for food preservation. Removable front thermometer panel and grille allows for easy access to complete lift-out refrigeration system.

CHARACTERISTICS	CBR84-1
Net Capacity	17.5
Width, Overall (in.)	84"
Depth, Overall (inc. Handles)	32"
Depth, Drawer(s)	57 1/4"
Height, Overall (in.)	26 3/4"
No. of Drawers	4
Top Load Rating (lbs.)	800

**ELECTICAL DATA**

Cabinet Voltage	115/60/1
NEMA Plug	5-15P
Total Amperes	4.5

**NOTE:** Plug style, voltage and full load amps may vary depending on certain options selected such as optional voltages and

**REFRIGERATION DATA**

Condensing Unit Size	1/3 HP
Refrigerant	R-134A

CRATED DIMENSIONS	LBS.
Two Section	598

Remote units use R-404A refrigerant standard and come with 6" legs

**Note:** In order to provide peak operating performance the cabinet must have a 2 inch all around clearance and 12 inches above the top of the condensing unit. This ensures an adequate air supply and space for routine maintenance and/or service if required.

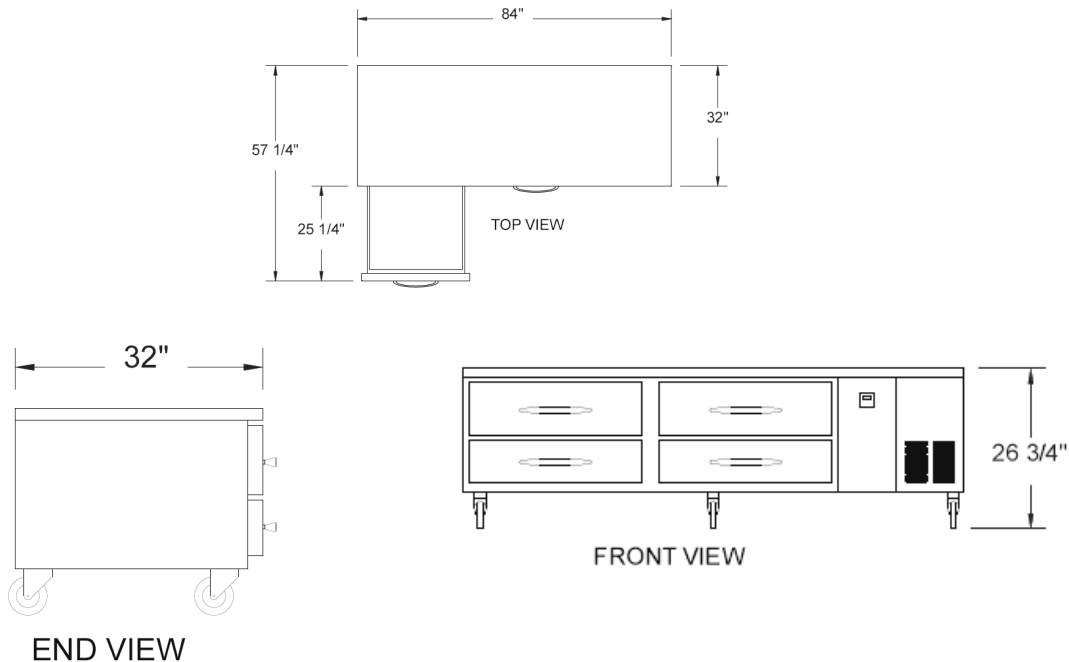

We reserve the right to change specifications and product design without notice. Such revisions do not entitle the buyer to corresponding changes, improvements, additions or replacements for previously purchased equipment. Dimensional tolerances +/- 1/4". Metric dimensions (MM)