

BIG TOP SANDWICH PREP TABLES WITH DRAWERS

VSPD48-18B-2

- Equipped with Secure-Temp 1.0™ Technology™
- 3 Year Parts & Labor Warranty Plus an Additional 2 Year Compressor Warranty
- Exclusive 2 Year Warranty on Santoprene Door Gaskets

VICTORY ULTRASPEC™
FEATURING: **SecureTemp™**
1.0

Secure-Temp 1.0™ is the industry's first and only full service temperature monitoring solution for your kitchen. Secure-Temp 1.0™ is standard on all Victory models and is HACCP compliant & meets NAFEM's data protocol.

There are NO software or monthly monitoring fees.
Optional add on kits are available for additional units.

STANDARD FEATURES

- Secure-Temp 1.0™ Technology
- Front-Breathing Refrigeration System
- Full Electronic Control
- Expansion Valve Technology
- Stainless Steel Exterior/Stainless Steel Interior
- Santoprene Door Gaskets with Exclusive 2 Year Warranty
- Environmentally Friendly R134A Refrigerant
- CFC Free Foamed In-Place Polyurethane
- Self-Closing Doors with 120° Hold Open feature
- 2 Epoxy Coated Shelves Standard Per Door Section
- Heavy Duty Stainless Steel Drawer Frames
- Telescoping Drawers Slides with Locking Mechanism
- Upper Pull-Out Drawers Accommodate 4" Deep Pans *(pans not included)*
- Lower Pull-Out Drawers Accommodate 6" Deep Pans *(pans not included)*
- Heavy Duty pan divider supports supplied
- Hinged, Insulated Flat, Lift Up Lids
- Locking Divider Bars
- Stainless Steel Pan Dividers
- 10" Wide Plastic Cutting Board
- 6" Casters, 2 With Brakes, Standard

IMAGE COMING SOON
VSPD48-18B-2

OPTIONS & ACCESSORIES

- ADA Compliant 3" Diameter Casters
- 6" Overall Height Adjustable SS Legs
- Single and Double Overshelves
- Stainless Steel Back
- Cylinder Locks
- Optional Voltages: 220/50/1, 220/60/1



CABINET CONSTRUCTION

Exterior construction includes heavy-duty stainless steel finish on front, sides, top, door(s) and grille. Removable hoods and insulated lid assemblies are made of matching stainless steel. Cabinet back and bottom are constructed of galvanized steel. Interior liner is made of aluminum for superior resistance to corrosion.

Cabinet insulation is CFC free foamed-in-place polyurethane of two-inch minimum thickness. Six-inch casters, 2 with brakes, are standard. Legs are available as an option.

Composite cutting board supplied with cabinet is 10" wide. It is readily removable for cleaning. Two epoxy-coated steel wire shelves per section are supplied as standard. Pans furnished are 4" deep and made of polycarbonate plastic.

DOOR CONSTRUCTION

Doors are mounted to face of cabinet on cartridge style hinges permitting them to self-close under their own weight. Hinges also allow doors to stay open 120° and permit easy door removal for service and cleaning if required. A plug in type vinyl magnetic gasket is attached to each door for positive seal. Door handle contoured to permit easy opening of doors with fingers from both top and bottom of handle.

DRAWER CONSTRUCTION

Drawer frames are constructed of heavy-duty stainless steel and are supported on heavy-duty telescoping drawer slides for maximum support of stored food products. Slides have locking mechanism to prevent from drawers being pulled off of cabinets. Upper pull-out drawers accommodate 4" deep pans. Lower pull-out drawers accommodate up to 6" deep pans. Heavy-duty pan divider supports are supplied. Food-service pans for drawers are not included. Snap-type vinyl magnetic gasket is attached to each drawer for positive seal.

REFRIGERATION SYSTEM

More robust refrigeration system provides added capacity and efficiency. Systems are designed using CFC free R134a refrigerant and expansion valve between condenser and evaporator. Recirculated, forced air from evaporator is moved under pans, which are recessed 2" from top of cabinet. Forced air over the condenser is drawn through grille under door as well as the back and bottom of cabinet. Automatic condensate evaporator is provided to eliminate the need of floor drains.

CHARACTERISTICS	VSPD48-18B-2
Net Capacity (cu. ft.)	13.9
Width, Overall (in.)	48"
Depth, Overall (in.)	31"
Depth, Door(s) Open 90° (in.)	52 1/8"
Height Overall (with lids open)	57 9/16"
No. Shelves	2
No. of 1/6 Pans	18
No. of Doors/Drawers	1/2

ELECTICAL DATA

Condensing Unit Voltage	115/60/1
Total Amperes	5

NOTE: Plug style, voltage and full load amps may vary depending on certain options selected such as optional voltages and compressor upgrades.

REFRIGERATION DATA

Condensing Unit Size	1/4 HP
Refrigerant	R-134A

CRATED WEIGHT	350 LBS
----------------------	---------

* Remote units use R-404A refrigerant standard and come with 6" legs

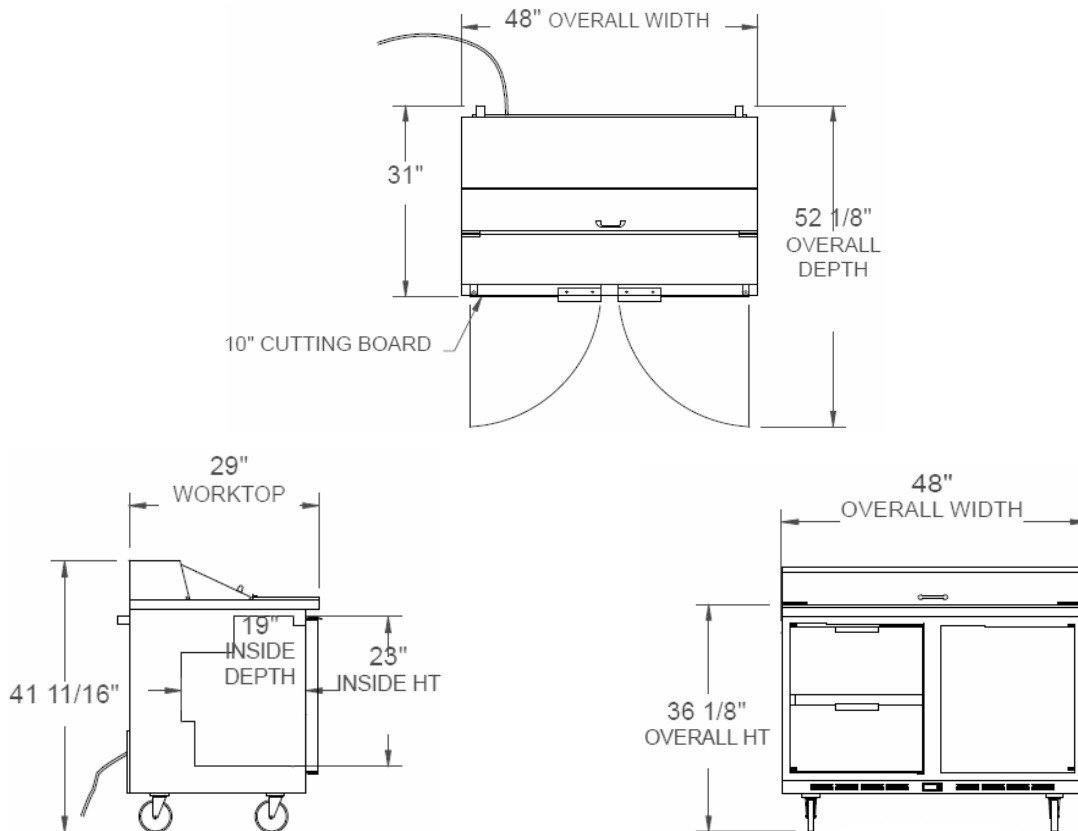

We reserve the right to change specifications and product design without notice. Such revisions do not entitle the buyer to corresponding changes, improvements, additions or replacements for previously purchased equipment. Dimensional tolerances +/- 1/4". Metric dimensions (MM)