

**BLAST CHILLER/SHOCK
FREEZER ROLL-IN/
ROLL-THRU**

VBCF-20-230
VBCF-20-230PT

- 3 Year Parts & Labor Warranty Plus an Additional 2 Year Compressor Warranty
- Exclusive 2 Year Warranty on Santoprene Door Gaskets

VICTORY

ULTRASPEC®

STANDARD FEATURES

- Soft and Hard, Timed or Core Probe Blast Chilling
- Soft and Hard, Timed or Core Probe Shock Freezing
- Automatic Recognition of Core Probe
- Multi Point Sensor Temperature Display Button
- Core Probe Heater Button
- HACCP Alarm Display Button
- Pre-Cooling Cycle Button
- Adjustable Evaporator Fan Speed Button
- Timed Manual Defrost Button
- Infinity Mode Program with Adjustable Set Point
- Automatic Conservation Mode at End of Cycle
- On Board Recipe Book with 68 Pre-Set Programs
- 99 Free Memory Positions for Custom Programs
- LCD Illuminated Temperature Display
- Real Time Clock
- RS 485 Connection
- One, High Precision Heated Multi Sensor Probe



VBCF-20-230

OPTIONS & ACCESSORIES

- Printer Kit or USB Data Recorder/Interface
- UV Sterilization Lamp
- Single Sensor Probes (up to 4 possible)
- Change Door Swing



VBCF CABINET CONSTRUCTION

AISI 30418/10 exterior and interior. Die-formed interior floor has rounded corners and central drain for easy cleaning. High density foamed in place CFC and HCFC free expanded polyurethane insulation (3.2" thick). Anti-condensation perimeter heating around door opening. Nontoxic epoxy coated evaporator coil. Internal bumpers and external guards protect the cabinet interior and the control panel from mobile carts.

VBCF DOOR CONSTRUCTION

Ergonomic door handle, safety panic button and outside lock, and rubber sweeper gasket.

VBCF REFRIGERATION SYSTEM

The self-contained refrigeration system uses R404A refrigerant. Evaporator is fitted with high velocity fans for maximum cooling efficiency. Indirect air flow assures highest product quality.

VBCF INTERIOR STORAGE ARRANGEMENTS

Accepts mobile carts— 26"W x 32"D x 74"H. For pan capacity, see model characteristics chart.

VBCF ELECTRONIC CONTROL SYSTEM

Electronic control with LCD/color display insures precise control of Blast Chilling (194° F to 37° F in 90 Minutes) or Shock Freezing (194° F to 0° F in 240 Minutes) Cycles. One touch hard and soft automatic blast chilling or shock freezing cycles based either on core probe temperature or timed cycle. Automatic recognition of the core probe and automatic conservation mode at the end of a cycle. One touch display of HACCP Alarms (power failure, cycle time out of HACCP required time, high temp, low temp) recorded in memory. The real time clock provides date, time, and duration of HACCP alarms (power failure, cycle time out of HACCP required time, high temp, low temp) recorded in memory. Will record up to 10 alarm events before over writing the first alarm and will keep the data for a minimum of 48 hours in case of a power failure. On board program memory holds 99 total programs. Adjustable Evaporator Fan Speed button allows for regulation of the fan during the blast chilling or shock freezing cycle. Compressor protected by overload cut-out with automatic reset. Micro-switch control cuts out the evaporator fan and compressor whenever the door is opened.

CHARACTERISTICS	VBCF-20-230	VBCF-20-230PT
Width, Overall (in.)	47.2	47.2
Depth, Overall (in.)	45.3	50.7
Height, Overall (with legs, in.)	87.8	87.8
Depth, Door Open 90°	74	74
Clear Door Height (in.)	75.6	75.6
Clear Door Width (in.)	26.4	26.4
Internal Depth (in.)	33.5	33.5
Wall Thickness (in.)	3.1	3.1
Sheet Pan Cart Capacity (18"x26")	20	20
Steam Table Pan Cart Capacity (12"x20")	20	20
Chilling Capacity in 90 min (lbs.)	230	230
Freezing Capacity in 240 min (lbs.)	150	150
Capacity Mobile Cart(s)	1 GN 1/1	1 GN 1/1

ELECTRICAL DATA

Cabinet Voltage	208-240/60/1	208-240/60/1
NEMA Plus	N/A	N/A
Total Amperes	5.7	5.7

REFRIGERATION DATA

Refrigerant	R404A	F404-A
Refrigerant Capacity (W*)	6750	6750
BTUH	24891	24891
Climate Class	T	T

CRATED DIMENSIONS

Crated H x W x D (in.)	91x51x58	91x51x58
Crated Weight (lbs.)	1063	1096
Uncrated Weight (lbs.)	770	792

VBCF Evap. Temp. -10° F, Ambient Temp. 90° F

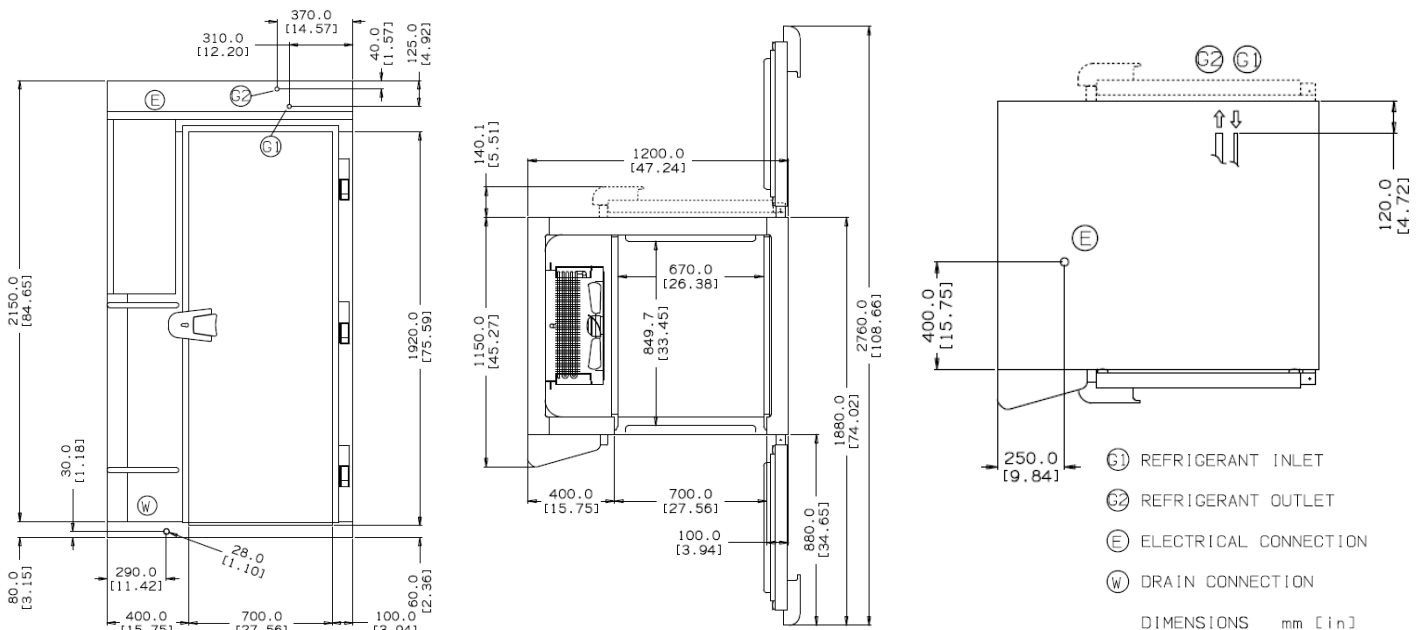

We reserve the right to change specifications and product design without notice. Such revisions do not entitle the buyer to corresponding changes, improvements, additions or replacements for previously purchased equipment. Dimensional tolerances +/- 1/4". Metric dimensions (MM)