

# VICTORY<sup>®</sup>

## ULTRASPEC

PROJECT: \_\_\_\_\_

ITEM # \_\_\_\_\_ QTY: \_\_\_\_\_

MODEL # \_\_\_\_\_

AIA # \_\_\_\_\_ SIS # \_\_\_\_\_

EXTRA WIDE DUAL TEMP SOLID DOOR REACH-IN REFRIGERATOR/FREEZER

### EXTRA WIDE DUAL TEMP SOLID DOOR REACH-IN REFRIGERATOR/FREEZER

### RFS-2D-S1-EW-HC



#### CABINET CONSTRUCTION

- Stainless Steel Exterior And Interior
- Refrigerator Is On The Left And Freezer Is On The Right
- Stay-Open Door Feature For Easy Product Loading
- 20 Gauge Stainless Steel Door
- Magnetic Door Switch Automatically Activates Interior LED Light
- Heavy-Duty Cylinder Locks
- Stainless Steel Interior Door Liner
- Insulated Partition Wall Separates Compartments
- One Piece, Snap-In Magnetic Door Gaskets
- Low Profile Vertical Door Handles
- Hinged Front Shroud
- Energy Saving Thermal Breaker
- Stainless Steel Breaker Caps
- 6 Silver Freeze Wire Shelves
- 6" High Adjustable Stainless Steel Legs
- 8' Cord And Plug (see electrical data for details)

#### FEATURES

- Full Electronic Control With Touchpoint Interface
- Expansion Valve Technology
- Manager's Lockout Feature
- Anti-Condensate Door Perimeter Heaters
- Variable Speed Compressor Technology

#### REFRIGERATION

- Refrigeration System Uses R-290 Refrigerant To Comply With All Environmental Concerns
- Hot Gas Condensate Evaporator
- Adaptive Defrost For Reduced Energy Consumption And More Consistent Product Temperatures
- Epoxy Coated Evaporator Coil, Located Out Of The Food Zone
- Refrigerator Capable Of Maintaining Product Temperature 36°F To 38°F
- Freezer Capable Of Maintaining Product Temperature -10°F



- ▶ 3 Year Parts & Labor Warranty Plus An Additional 4 Year Compressor Warranty
- ▶ Exclusive 2 Year Warranty On Magnetic Door Gaskets
- ▶ Lifetime Warranty On Handles & Hinges (parts only)



Please verify qualifying units by visiting:  
[www.energystar.gov/cfs](http://www.energystar.gov/cfs)

#### OPTIONS & ACCESSORIES

- Secure-Temp™ Technology
- Stainless Steel Case Back
- Exterior Door Laminate
- Glass Door Models
- Stainless Steel Kick Plate
- Additional Shelves
- Heat Shield (left, right)
- 6" Casters Or 6" Seismic Legs
- Optional Top Freezer/Bottom Refrigerator
- Tray Slides
- Door Swing Orientation (at time of order)
- Refrigerator FlexTemp Models Maintain Between 28°F And 38°F
- Freezer FlexTemp Models Maintain Between 0°F And 20°F
- Correctional Package
- Remote Models\* (6" legs only) (refrigerant must be specified at time of order, see note)

3779 Champion Blvd, Winston-Salem, NC 27105

ph: (888) 845-9800 | fax: (800) 253-5168

Sales@VictoryRefrigeration.com | VictoryRefrigeration.com

Rev. 8/27/21 Printed in U.S.A.

APPROVAL: \_\_\_\_\_ DATE: \_\_\_\_\_

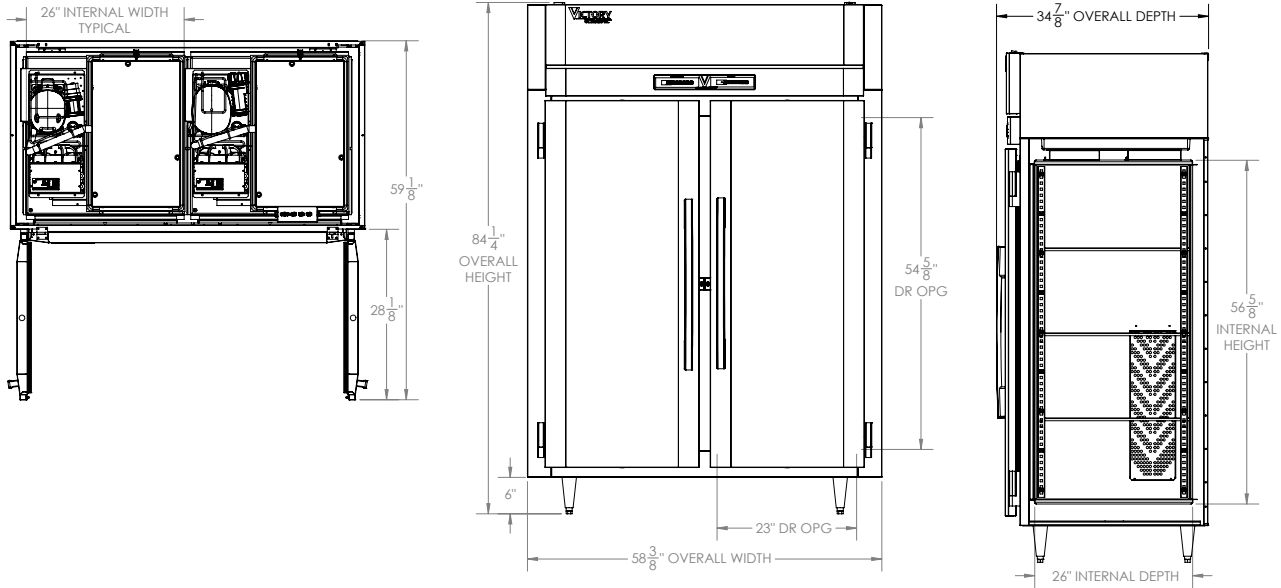

We reserve the right to change specifications and product design without notice. Such revisions do not entitle the buyer to corresponding changes, improvements, additions or replacements for previously purchased equipment. Dimensional tolerances +/- 1/4". Metric dimensions (MM)

12" Top and 3" rear clearance is required

CHARACTERISTICS		ELECTRICAL DATA		SHIPPING DETAILS	
Net Capacity (cubic ft.)	R 24.08 - F 24.08	Cabinet Voltage**	115/60/1	Height	88
Width, Overall (in.)	58 3/8"	Total Amperes	R 6.5 - F 9.1	Width	66"
Depth, Overall (with handle)	34 7/8"	NEMA Plug (8' cord)	(2) 5-15P	Depth	41"
Height Overall (6" legs)	84 1/4"	<b>REFRIGERATION DATA</b>		Crated Weight	700 lbs
Depth, Door Open 90°	59 1/8"	Condensing Unit Size, HP	R 1/3 - F 3/4	*NOTE: Remote units are field wired and come with 6" legs. Refrigerant must be specified at time of order.	
Door Opening (in.)	23" x 54 5/8"	Refrigerant	R-290		
No. Of Doors/Shelves	2/6	Capacity (BTU/HR) (100°F/20°F)	Variable Speed Technology		

\*\* NOTE: This unit utilizes variable speed compressor technology. The compressor can experience nuisance tripping on Class A GFCI outlets which have a trip limit of 4 mA to 6 mA. To avoid this issue in a location that requires GFCI circuit protection, Victory recommends using a HUBBELL Model Number GFRST83W 20A Heavy Duty Hospital Grade Self-Test GFCI Receptacle.

3779 Champion Blvd, Winston-Salem, NC 27105 | ph: (888) 845-9800 | fax: (800) 253-5168

Sales@VictoryRefrigeration.com | VictoryRefrigeration.com

Rev. 8/27/21 Printed in U.S.A.

an Ali Group Company



The Spirit of Excellence