



PROJECT: _____
 ITEM # _____ QTY: _____
 MODEL # _____
 AIA # _____ SIS # _____

PIZZA PREP TABLE

PIZZA PREP TABLE
VPP46HC



CABINET CONSTRUCTION

- Stainless Steel Exterior (galvanized back and bottom)
- Aluminum Interior
- 22 Gauge Stainless Steel Top
- Hinged, Insulated, Flat Lift-Up Lids
- One-Piece, Snap-In Magnetic Door Gasket
- Heavy-Duty Aluminum Pan Liner
- 8' Cord And Plug (see electrical data for details)

FEATURES

- Full Electronic Control
- Chrome Lift Off Hinges
- Low Profile Horizontal Door Handle
- Epoxy Coated Shelves (2 per section)
- Stay-Open Door Feature For Easy Product Loading
- Top Accommodates Up To 6" Deep Food Service Pans (pans not included)
- Removable 19" Wide Cutting Board
- 3" Casters Two With Locks

REFRIGERATION

- Refrigeration System Uses R-290 Refrigerant To Comply With All Environmental Concerns
- Side Mounted Refrigeration System For Serviceability
- Adaptive Defrost For Reduced Energy Consumption And More Consistent Product Temperatures
- Epoxy Coated Evaporator Coil
- Refrigerator Capable Of Maintaining Product Temperature 36°F To 38°F

- ▶ **3 Year Parts & Labor Warranty Plus An Additional 4 Year Compressor Warranty**
- ▶ **Exclusive 2 Year Warranty On Magnetic Door Gaskets**
- ▶ **Lifetime Warranty On Handles (parts only)**



Please verify qualifying units by visiting:
www.energystar.gov/cfs

OPTIONS & ACCESSORIES

- | | | |
|----------------------------|----------------------------------|--|
| • Stainless Steel Interior | • Additional Shelves | • 6" Casters, 6" Legs Or 6" Seismic Legs |
| • Stainless Steel Back | • Shelf Clips | • Compressor On Left (specify at time of order) |
| • Secure-Temp™ Technology | • Single & Double Overshelf Unit | • Remote Models* (6" legs only) |
| • Exterior Door Laminate | • Bun Tray Rack (per door) | (refrigerant must be specified at time of order, see note on back on page) |
| • Door Lock | • Tray Slide Kit | |

3779 Champion Blvd, Winston-Salem, NC 27105

ph: (888) 845-9800 | fax: (800) 253-5168

Sales@VictoryRefrigeration.com | VictoryRefrigeration.com

Rev. 10/15/21 Printed in U.S.A.

APPROVAL: _____ DATE: _____

VICTORY PIZZA PREP TABLE

VPP46HC

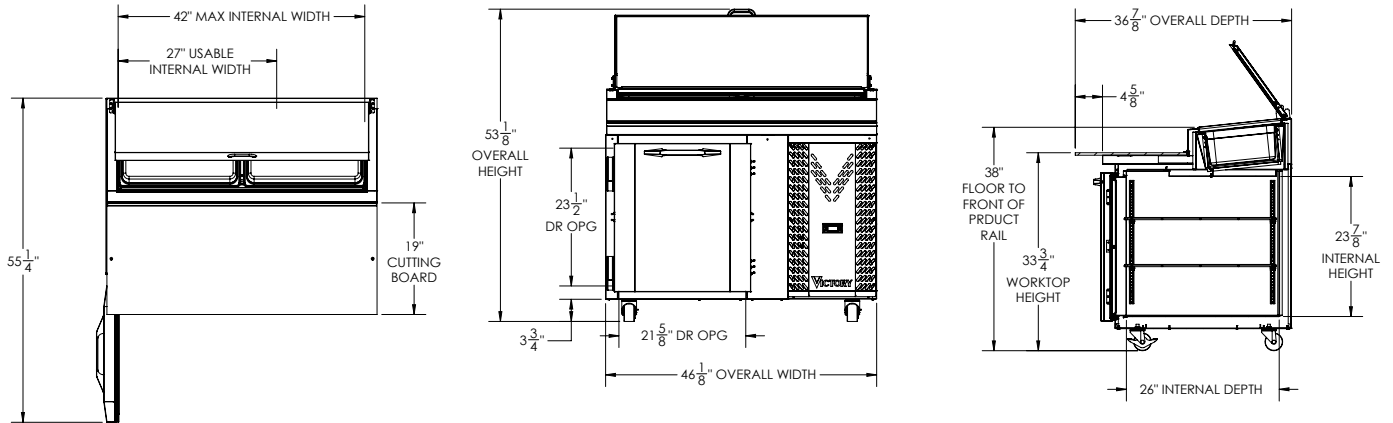

We reserve the right to change specifications and product design without notice. Such revisions do not entitle the buyer to corresponding changes, improvements, additions or replacements for previously purchased equipment. Dimensional tolerances +/- 1/4". Metric dimensions (MM)

CHARACTERISTICS		ELECTRICAL DATA		SHIPPING DETAILS	
Net Capacity (cubic ft.)	12.02	Cabinet Voltage	115/60/1	Height	48"
Width, Overall (in.)	46 1/8"	Total Amperes	4.5	Width	49"
Depth, Overall (with cutting board)	36 7/8"	NEMA Plug (8' cord)	5-15P	Depth	37"
Height Overall (with casters)	53 1/8"	REFRIGERATION DATA		Crated Weight	344 lbs
Depth, Door Open 90°	55 1/4"	Condensing Unit Size, HP	1/2	*NOTE: Remote units are field wired and come with 6" legs. Refrigerant must be specified at time of order.	
Door Opening (in.)	21 5/8" x 23 1/2"	Refrigerant*	R-290		
No. Of Doors/Shelves	1/2	Capacity (BTU/HR) (100°F/20°F)	2940		
		Heat Rejection (BTU/HR)	4410		
		Charge (lbs/grams)	0.231/105		

3779 Champion Blvd, Winston-Salem, NC 27105 | ph: (888) 845-9800 | fax: (800) 253-5168

Sales@VictoryRefrigeration.com | VictoryRefrigeration.com

Rev. 10/15/21 Printed in U.S.A.

an Ali Group Company



The Spirit of Excellence