

VICTORY

PROJECT: _____
ITEM # _____ QTY: _____
MODEL # _____
AIA # _____ SIS # _____

PIZZA PREP TABLE WITH DRAWERS

PIZZA PREP TABLE WITH DRAWERS VPPD67HC-2



CABINET CONSTRUCTION

- Stainless Steel Exterior (galvanized back and bottom)
- Aluminum Interior
- Hinged, Insulated, Flat Lift-Up Lids
- One-Piece, Snap-In Magnetic Door/Drawer Gaskets
- Heavy-Duty Aluminum Pan Liner
- 8' Cord And Plug (see electrical data for details)

REFRIGERATION

- Refrigeration System Uses R-290 Refrigerant To Comply With All Environmental Concerns
- Side Mounted Refrigeration System For Serviceability
- Adaptive Defrost For Reduced Energy Consumption And More Consistent Product Temperatures
- Epoxy Coated Evaporator Coil
- Refrigerator Capable Of Maintaining Product Temperature 36°F To 38°F

FEATURES

- Full Electronic Control
- Chrome Lift Off Hinges
- Low Profile Horizontal Door/Drawer Handles
- Epoxy Coated Shelves (2 per section)
- Stay-Open Door/Drawer Feature For Easy Product Loading
- Heavy-Duty Stainless Steel Drawer Frames
- Heavy-Duty Pan Divider Supports Supplied
- Locking Divider Bars (drawers only)
- Top Accommodates 6" Deep Food Service Pans (pans not included)
- Accommodates 6" Deep Full Size Food Service Pans In Both Upper And Lower Drawers (pans not included)
- Heavy-Duty, Telescoping Drawer Slides With Locking Mechanism
- 275 lbs Drawer Load Rating (per drawer)
- Removable 19" Wide Cutting Board
- 3" Casters Two With Locks

- ▶ **3 Year Parts & Labor Warranty**
Plus An Additional 4 Year Compressor Warranty
- ▶ **Exclusive 2 Year Warranty On Magnetic Door & Drawer Gaskets**
- ▶ **Lifetime Warranty On Handles, Drawers & Drawer Slides (parts only)**



Please verify qualifying units by visiting:
www.energystar.gov/cfs

OPTIONS & ACCESSORIES

- Stainless Steel Interior
- Additional Shelves
- 6" Casters, 6" Legs Or 6" Seismic Legs
- Stainless Steel Back
- Shelf Clips
- Compressor On Left (specify at time of order)
- Secure-Temp™ Technology
- Single & Double Overshelf Kit
- Remote Models* (6" legs only)
(refrigerant must be specified at time of order, see note on back on page)
- Exterior Door Laminate
- Bun Tray Rack (per door)
- Door/Drawer Locks
- Tray Slide Kit

3779 Champion Blvd, Winston-Salem, NC 27105

ph: (888) 845-9800 | fax: (800) 253-5168

Sales@VictoryRefrigeration.com | VictoryRefrigeration.com

Rev. 10/18/21 Printed in U.S.A.

APPROVAL: _____ DATE: _____

VICTORY PIZZA PREP TABLE WITH DRAWERS

VPPD67HC-2

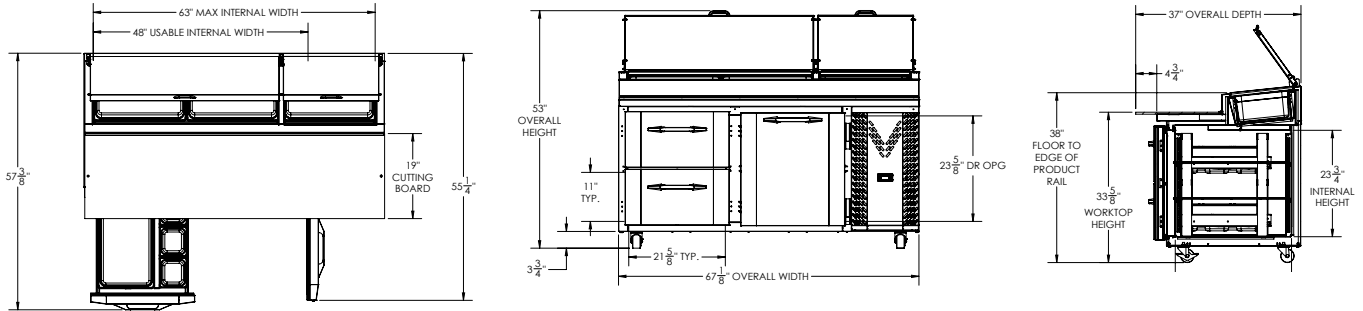

We reserve the right to change specifications and product design without notice. Such revisions do not entitle the buyer to corresponding changes, improvements, additions or replacements for previously purchased equipment. Dimensional tolerances +/- 1/4". Metric dimensions (MM)

CHARACTERISTICS		ELECTRICAL DATA		SHIPPING DETAILS	
Net Capacity (cubic ft.)	20.68	Cabinet Voltage	115/60/1	Height	48"
Width, Overall (in.)	67 1/8"	Total Amperes	4.5	Width	70"
Depth, Overall (with cutting board)	37"	NEMA Plug (8' cord)	5-15P	Depth	45"
Height Overall (with casters)	53"	REFRIGERATION DATA		Crated Weight	512 lbs
Depth, Drawer Extended	57 3/8"	Condensing Unit Size, HP	1/2	*NOTE: Remote units are field wired and come with 6" legs. Refrigerant must be specified at time of order.	
Depth, Door Open 90°	55 1/4"	Refrigerant*	R-290		
Drawer Opening (in.)	21 5/8" x 11"	Capacity (BTU/HR) (100°F/20°F)	2940		
Door Opening (in.)	21 5/8" x 23 5/8"	Heat Rejection (BTU/HR)	4410		
No. Of Doors/Shelves/Drawers	1/2/2	Charge (lbs/grams)	0.231/105		

3779 Champion Blvd, Winston-Salem, NC 27105 | ph: (888) 845-9800 | fax: (800) 253-5168

Sales@VictoryRefrigeration.com | VictoryRefrigeration.com

Rev. 10/18/21 Printed in U.S.A.

an Ali Group Company



The Spirit of Excellence