



Over 90 Years Of Quality Foodservice  
Products And Service

Job \_\_\_\_\_ Item No. \_\_\_\_\_

## Universal Ventless Hood

MODEL  WVU-96



Model WVU-96  
(equipment sold separately)

### DESCRIPTION

Wells Universal hoods are Certified Type-1 compliant, ANSI UL710B approved recirculation hood systems and feature completely self-contained 4 stage air filtration and fire suppression systems. They do not require venting outside making it possible to cook in non-traditional locations or when traditional Type-1 hoods and duct-work are impractical, restricted or too expensive. Operators can mix and match various electric cooking equipment under the hood such as fryers, ovens, griddles, steamers and more - providing greater flexibility and production.

### SPECIFICATIONS

**Fire Protection** – Completely self contained ANSUL® R-102 system includes ANSUL® tank, nitrogen cartridge, ANSUL® sopanifier, piping, heat sensors, ANSUL® drops, nozzles, and movable manual pull station. Manual pull can be relocated to the egress position or an additional station can be added by an authorized ANSUL® representative. Front access for easy fire system maintenance. Fire protection system meets NFPA 96 Chapter 13 and UL300. Fire protection system must be charged and certified by ANSUL® Authorized distributor after installation and before first use (operator's responsibility).

**Filtration** – Completely self-contained 4-Stage filtration process reduces emissions below that allowed in NFPA 96 and ANSI UL710B using the EPA 202 test method and includes stainless steel grease baffle filter with grease cup, fiberglass pre-filters, High efficiency filter/ carbon-charcoal filter pack. All filters are easily removable without tools. Air flow sensors continually monitor air flow optimizing performance and grease removal while an interlock system will not allow cooking appliances to function if filters are missing, clogged or in the event of a fire.

**Cooking Appliances** – Only electrically heated appliances are acceptable for installation. Cooking equipment is optional from Wells or other manufacturers. Appliances must be installed as per manufacturers instructions and controlled by the hood equipment interface contactor through a customer supplied contactor which will disable cooking equipment in the event of fire or hood malfunction. Shunt trips are not allowed. For size, temperature and KW limits see back page or manual.

**Exhaust and Air Flow** – Exhaust air may be horizontal or vertical. Hoods are shipped for horizontal discharge and are field convertible for vertical discharge. Typical airflow through the hood is 3000 CFM. A minimum of 1600 cubic feet of fresh air per minute (200 cubic feet per linear foot of hood) is required into the area to comply with the Universal mechanical code and for the dilution of cooking aromas.

### STANDARD FEATURES

- Completely self-contained, 4-stage air filtration system reduces emissions below that allowed in NFPA 96 and ANSI UL710B using the EPA 202 test method. Maximum grease emissions are less than .0029 LB/HR/ FT (pounds per hour per foot)
- Completely self-contained fire protection system
- Very quiet with only 68 dBA average
- Interlock system will disable cooking appliances if filters are missing, clogged or in the event of a fire
- Airflow sensors continually monitor airflow for optimizing performance and grease removal
- Illuminated early-warning system to monitor filter replacement
- Six LED lights producing 500 lumens each for improved visibility - light color temperature (cool white) 6000K
- Stainless steel construction for strength, durability and ease of cleaning
- Fits through a 36" wide door opening
- 6" to 8" adjustable legs (adjustable by 2" for leveling)
- Universal systems are movable making them ideal for leased properties
- Available in 208/240V, 1Ø
- Limited two-year parts and one year labor warranty

### OPTIONS & ACCESSORIES

- Pre-filters
- 10" to 12" adjustable legs (adjustable by 2" for leveling)
- High-Efficiency / carbon-charcoal filter packs
- Vent Collar (for direct venting of heat out of the space)
- Stainless Steel Rear panels

### CERTIFICATIONS



UL CAT. YZCT RECIRCULATING SYSTEM FILE NO. M448408

SHEET NO. WELLS-WVU-96\_06/16



Over 90 Years Of Quality Foodservice  
Products And Service

# Universal Ventless Hood

## MODEL □ WVU-96

### GENERAL LAYOUT DATA SANITATION



NSF/ANSI 2 UL710B

### MODEL WVU-96SS UNIVERSAL VENTLESS HOOD SYSTEM

VOLTAGE AC 60 HZ	AMPS 1 PH	HORSE POWER	TYPICAL AIRFLOW	MAX GREASE EMISSIONS	CLEARANCE TO COMBUSTIBLES	SOUND LEVEL dBA AVG	UNDER HOOD LED LIGHTING
208/240	8.0	1.5	3000 CFM	.0024 LB/HR/FT	N/A	70	2970 LUMENS

UL CAT. YZCT RECIRCULATING SYSTEM FILE NO. MH48408

SPECIAL ENVIRONMENTAL NOTICE: THE HOOD SYSTEM IS DESIGNED TO REDUCE EMISSIONS BUT WILL NOT COMPLETELY ELIMINATE COOKING AROMAS. AIR EXCHANGE AT THE INSTALLATION SITE MUST COMPLY WITH REQUIREMENTS OF THE LOCAL JURISDICTIONAL AUTHORITY. A MINIMUM OF 1600 CUBIC FEET OF FRESH AIR PER MINUTE INTO THE AREA IS RECOMMENDED TO ENSURE ADEQUATE DILUTION.

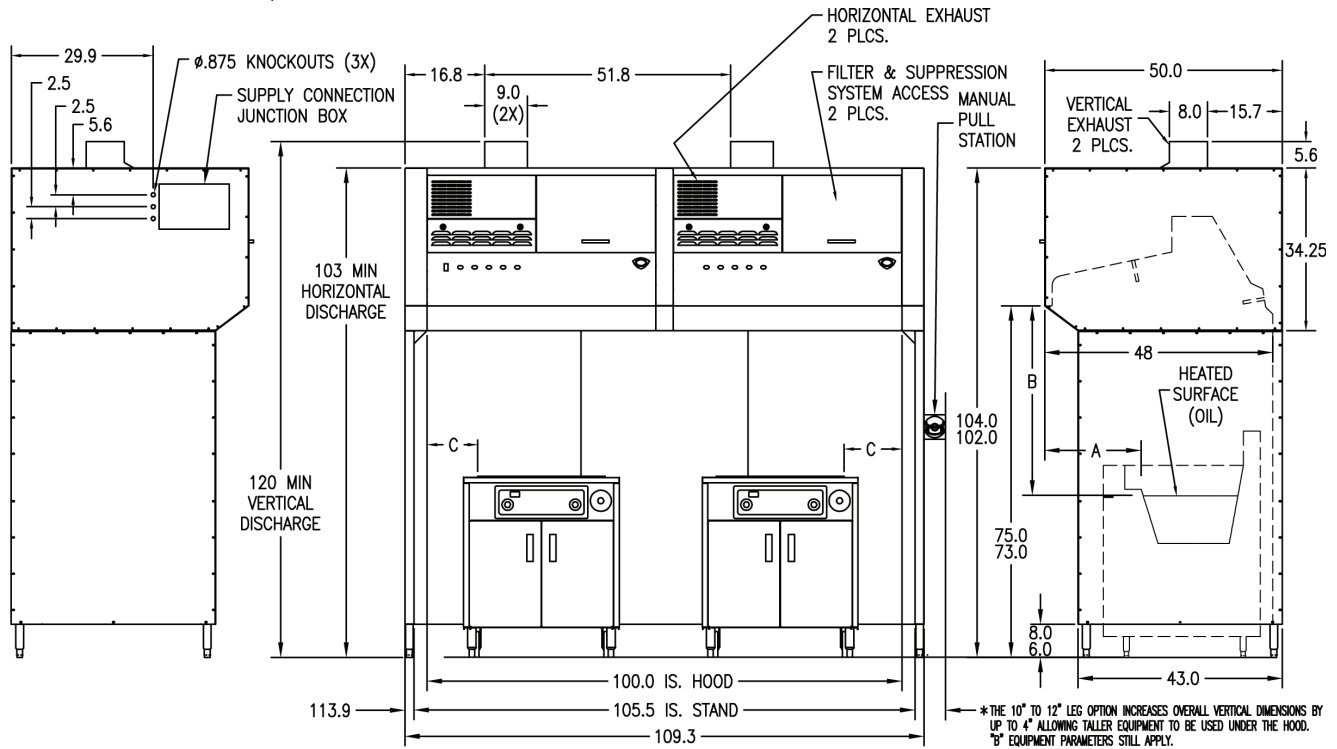

\*THE 10" TO 12" LEG OPTION INCREASES OVERALL VERTICAL DIMENSIONS BY UP TO 4" ALLOWING TALLER EQUIPMENT TO BE USED UNDER THE HOOD. "B" EQUIPMENT PARAMETERS STILL APPLY.

EQUIPMENT PARAMETERS APPLIANCE TYPE	MAXIMUM KW/FT	MAX COOKING TEMPRATURE	MAXIMUM SINGLE APPLIANCE HEATED COOKING SURFACE LENGTH	DIM A (3) MINIMUM	DIM B (4) MINIMUM	DIM B (4) MAXIMUM	DIM C (5) MINIMUM
FRYER	16.9	400	18	14 (EDGE OF OIL)	37	42	0
GRIDDLE	5.5	450	36	21 (EDGE OF HEATED PLATE)	37	42	1
RANGE (2) /HOTPLATE	5.5	N/A	48	21 (EDGE OF HEATED PLATTEN)	37	42	1
WOK	7.0	N/A	48	21 (EDGE OF HEATED SURFACE)	37	42	0
VERTICAL BROILER	7.0	N/A	25	20 (EDGE OF HEATED SURFACE)	10	N/A	0
OVEN	N/A	575	48	6 (FRONT EDGE OF DOOR)	8	N/A	0
BRAISING PAN/SKILLET (1)	4.5	550	48	14 (EDGE OF HEATED SURFACE)	37	42	0
CONVECTION OVEN	N/A	575	48	6 (FRONT EDGE OF DOOR)	8	N/A	0
STEAMER / COMBI OVEN	N/A	575	48	6 (TOP EDGE OF DOOR)	20	N/A	0
STEAM JACKETED KETTLE	16.9	450	48	14 (EDGE OF OF HEATED SURFACE)	30	42	0
SANDWICH GRILL (1)	4.5	550	36	18 (EDGE OF HEATED PLATTEN)	30	42	0
CONVEYOR OVEN	4.5	N/A	23	6 (EDGE OF HEATED SURFACE)	20	42	0

- (1) LID MUST NOT INTERFERE WITH SUPPRESSION NOZZLE DISCHARGE PATTERN.
- (2) PLUS OVEN KW IF APPLICABLE.
- (3) FRONT OF HOOD TO FRONT EDGE OF HEATED COOKING SURFACE.
- (4) BOTTOM FRONT EDGE OF HOOD TO HEIGHT OF HEATED COOKING SURFACE.
- (5) INSIDE OF HOOD SIDE TO EDGE OF COOKING SURFACE.

THE HOOD AND ALL UNDER HOOD APPLIANCES MUST BE INSTALLED IN ACCORDANCE WITH THE STANDARD FOR VENTILATION CONTROL AND FIRE PROTECTION OF COMMERCIAL COOKING OPERATIONS NFPA 96, THE NATIONAL ELECTRIC CODE NFPA 70 AND ALL LOCAL CODES WHERE APPLICABLE. ALL UNDER HOOD APPLIANCES MUST BE INSTALLED AS PER MANUFACTURER INSTRUCTIONS AND CONTROLLED BY THE HOOD EQUIPMENT SHUTOFF INTERFACE THROUGH A CUSTOMER SUPPLIED CONTACTOR. SEE THE INSTRUCTION MANUAL FOR INTERFACE CONNECTION OPTIONS. APPLIANCES MUST MEET EQUIPMENT PARAMETERS DESCRIBED ABOVE. ONLY ELECTRICALLY HEATED APPLIANCES ARE ACCEPTABLE FOR INSTALLATION. PRIOR TO OPERATION THE FIRE SUPPRESSION SYSTEM MUST BE CHARGED AND CERTIFIED BY AN ANSUL® AUTHORIZED DISTRIBUTOR. ADEQUATE SIDE CLEARANCE MUST BE PROVIDED FOR SUPPLY CONNECTION AND SUPPRESSION MANUAL PULL ACCESS. EXHAUST IS SHIPPED FOR HORIZONTAL DISCHARGE AND FIELD CONVERTIBLE FOR VERTICAL DISCHARGE.