

# STAINLESS STEEL UTILITY CARTS

ITEM NO. \_\_\_\_\_  
QUANTITY NO. \_\_\_\_\_  
JOB NO. \_\_\_\_\_  
SPEC NO. \_\_\_\_\_

## FEATURES & BENEFITS:

- Great cart for health care, schools, hotels, and correctional use.
- Heavy duty all welded construction. 16 Gauge shelves and tubing standard. Supports 500 lbs per shelf.
- Standard with 5" x 2" polyurethane plate casters at no additional charge. Units have a rolling capacity of 2800 lbs.
- Shelf clearance on 2 shelf cart has 23 1/2" spacing between shelves and 3 shelf cart has 11" spacing between shelves.
- 14 Gauge unit and custom sizes available upon request.
- Custom sizes available upon request.



UC-3-2133SS

## SPECIFICATIONS:

### SHELVES

16 Gauge Stainless Steel Sheet. 3 Lips hemmed up and 1 lip down.

### FRAME

Constructed of 16 Gauge, 1" square tubing. (2) 12" vertical bumpers mounted on tubing. Handle made of 1" round tubing with round bumpers on handle ends.

### CASTERS

Standard with 5" x 2" polyurethane plate casters. Mounted on 12 gauge wheel channel. 2 rigid and 2 swivel standard.

### OPTIONS:

- All swivel casters
- 4 Lips up on shelves
- Reinforced Shelves



Top View

*Laboratory Certification  
and Approval Symbols:*



141 Eileen Way • Syosset, NY 11791 • Tel: 1-800-444-3595 • Fax: 516-921-0538  
www.winholt.com • sales@winholt.com

PENNSYLVANIA • GEORGIA • TEXAS • CALIFORNIA



ITEM NO. \_\_\_\_\_  
 JOB NO. \_\_\_\_\_  
 SPEC NO. \_\_\_\_\_

# STAINLESS STEEL UTILITY CARTS

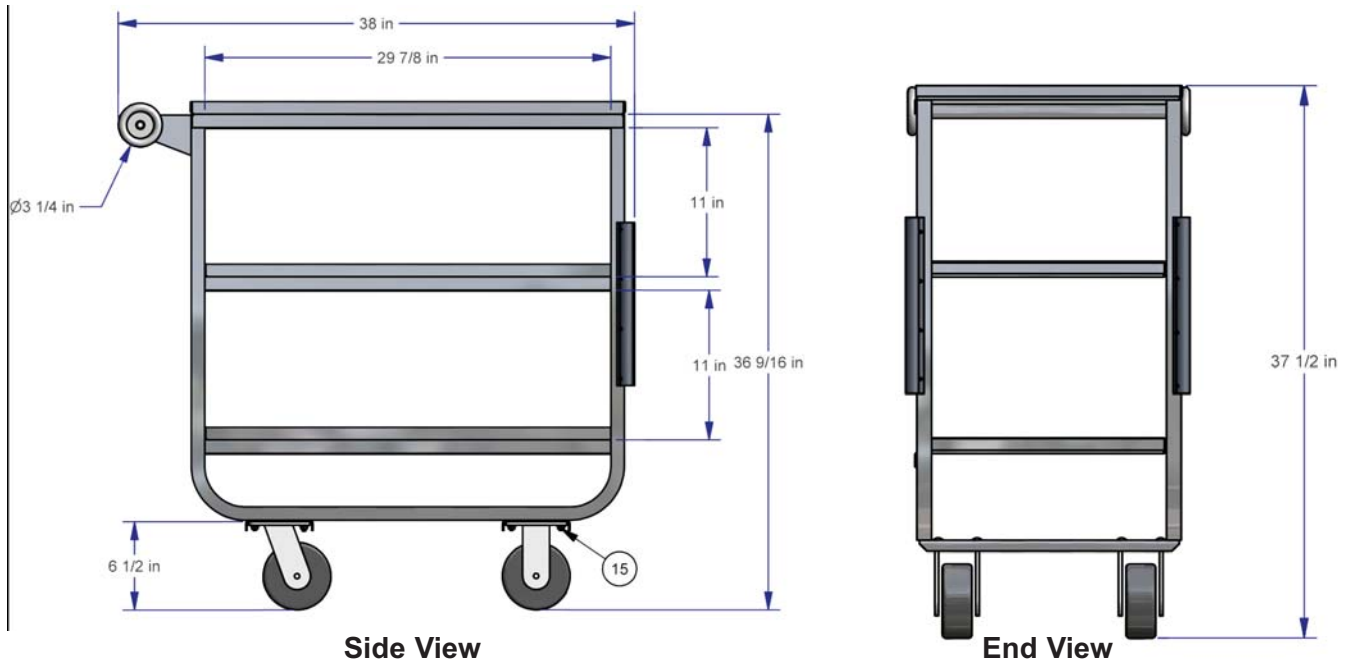
Model #	Overall Dimensions						Shelf Size (in)	Shelf Spacing (in)	Approximate Ship Weight	
	Width		Length		Height				(lb)	(kg)
	(in)	(mm)	(in)	(mm)	(in)	(mm)				
<b>2 Shelves</b>										
UC-2-1832SS	18	457	38	965	37.5	953	18" x 32"	23.5	70	32
UC-2-2133SS	21	533	39	991	37.5	953	21" x 33"	23.5	77	35
UC-2-2149SS	21	533	55	1397	37.5	953	21" x 49"	23.5	92	42
<b>3 Shelves</b>										
UC-3-1832SS	18	457	38	965	37.5	953	18" x 32"	11	84	38
UC-3-2133SS	21	533	39	991	37.5	953	21" x 33"	11	93	42
UC-3-2149SS	21	533	55	1397	37.5	953	21" x 49"	11	115	52

Win-Holt Equipment is a leading manufacturer of material & food handling equipment. Since 1946, retailers and restaurant chains have trusted Win-Holt's equipment to ensure increased productivity and efficiency in their operation. Multiple locations reduce logistics and transportation costs. All Win-Holt associates are dedicated to customer satisfaction.

For general sales and engineering information only. All units are subject to change without notice. Please consult factory for certified specifications.

141 Eileen Way • Syosset, NY 11791 • Tel: 1-800-444-3595 • Fax: 516-921-0538  
 www.winholt.com • sales@winholt.com