



Founded in 1946

Project: _____

Items: _____

Quantity: _____

Approval: _____

Date: _____

U-BOAT WITH SLANTED SHELVES

U-Boat[®] with Slanted Shelves

Model 300-60D/SDR

- Great for overstock merchandise.
- Narrow 18" width designed for use in busy aisles.
- Constructed of all welded steel, with a powder coated gray finish.
- Three slanted shelves with turned "up" lip to prevent run off.
- Two high-end, secure merchandise in place.
- Convenient Tool Box.
- Maneuvers easily on two 8" stationary center load wheels and four 4" swivel end casters. Six wheel design allows cart to swivel on its own radius.

Handy Tool
Box



Slant shelf with turned "up"
lip keeps merchandise
Visible and secure

300-60D/SDR



U-BOAT WITH SLANTED SHELVES



Founded in 1946

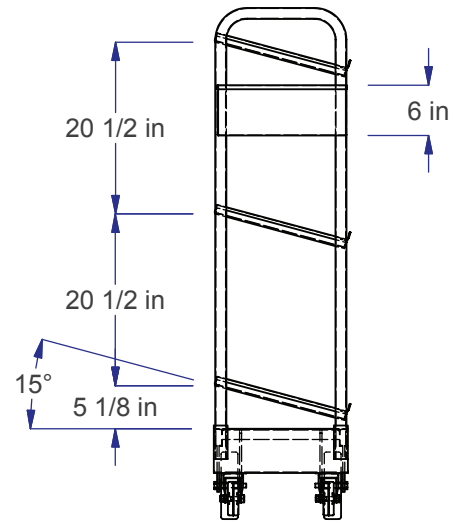
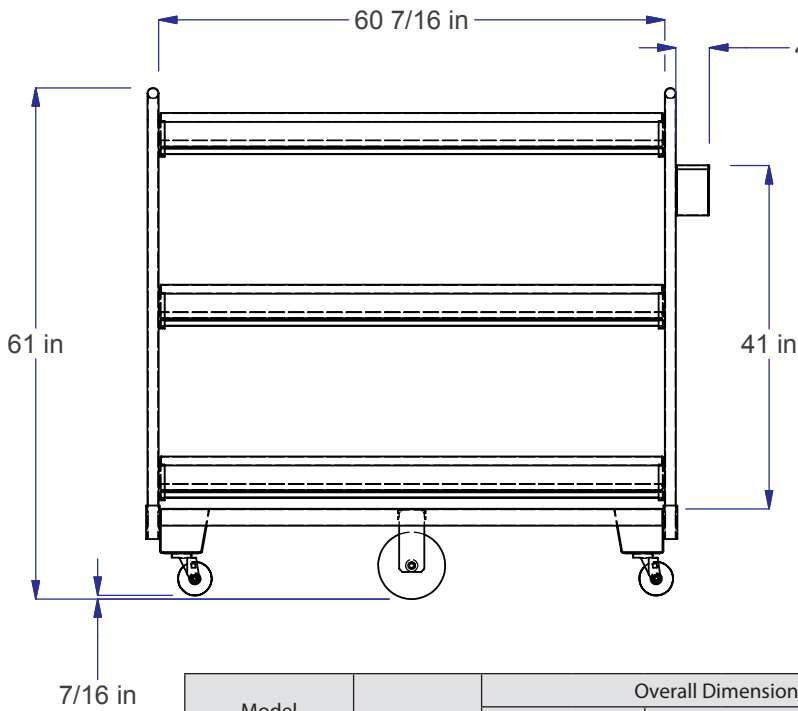
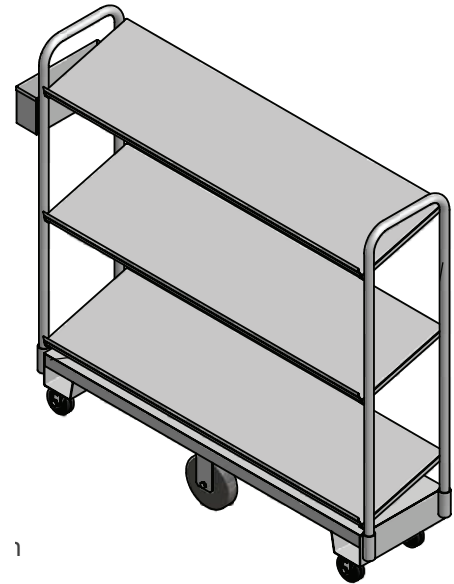
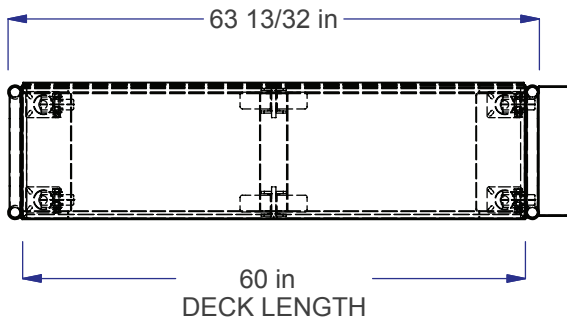

7/16 in

Model Number	Order#	Overall Dimensions						Capacity		Approx. Ship Wt	
		Width		Length		Height		(lb)	(kg)	(lb)	(kg)
		(in)	(mm)	(in)	(mm)	(in)	(mm)				
300-60D/SDR	268373	16	406	63	1,600	61	1,549	2,000	907	95	43

Caster Information:
 8" Polyurethane Center Wheel 7130 (122462)
 Swivel Plate Caster w/ 4" Polyurethane Wheel 7351 (123211)
 4" Polyurethane Wheel 7125 (122403)
 Freight Class: 70

In line with our poicy to continually improve our products, Winholt reserves the right to change materials and specifications without notice.

6.2014