



Founded in 1946

Project: _____

Items: _____

Quantity: _____

Approval: _____

Date: _____

ALUMINUM FOLDING U-BOAT

Folding U-Boat® Aluminum

- Light weight, aluminum cart
- Lifetime Warranty Against Rust
- Handles fold for upright storage.
- End Handles and Frame constructed of all welded steel, powder coated gray.
- Narrow 16" width, designed for use in busy aisles.
- Maneuvers easily on two 6" stationary center load wheels and four 5" polyurethane swivel end casters. Six wheel design allows cart to swivel within its own radius.



AL-300-60-FH

Model Number	Order#	Overall Dimensions						Capacity		Approx. Ship Wt	
		Width		Length		Height		(lb)	(kg)	(lb)	(kg)
		(in)	(mm)	(in)	(mm)	(in)	(mm)				
AL-300-60-FH	661407	16	406	63	1600	60 ^{1/2}	1524	1,500	680	92	41

Caster Information

6" Polyurethane Center Wheel 7417 (123351)

Swivel Plate Caster w/ 5" Polyurethane Wheel 738A (128784)

5" Polyurethane Wheel 7112 (122180)

Freight Class: 70

Winholt Equipment | 141 Eileen Way | Syosset, New York 11791
 Pennsylvania Texas California India China

800.444.3595 | 516.921.0538 fax | www.winholt.com



Founded in 1946

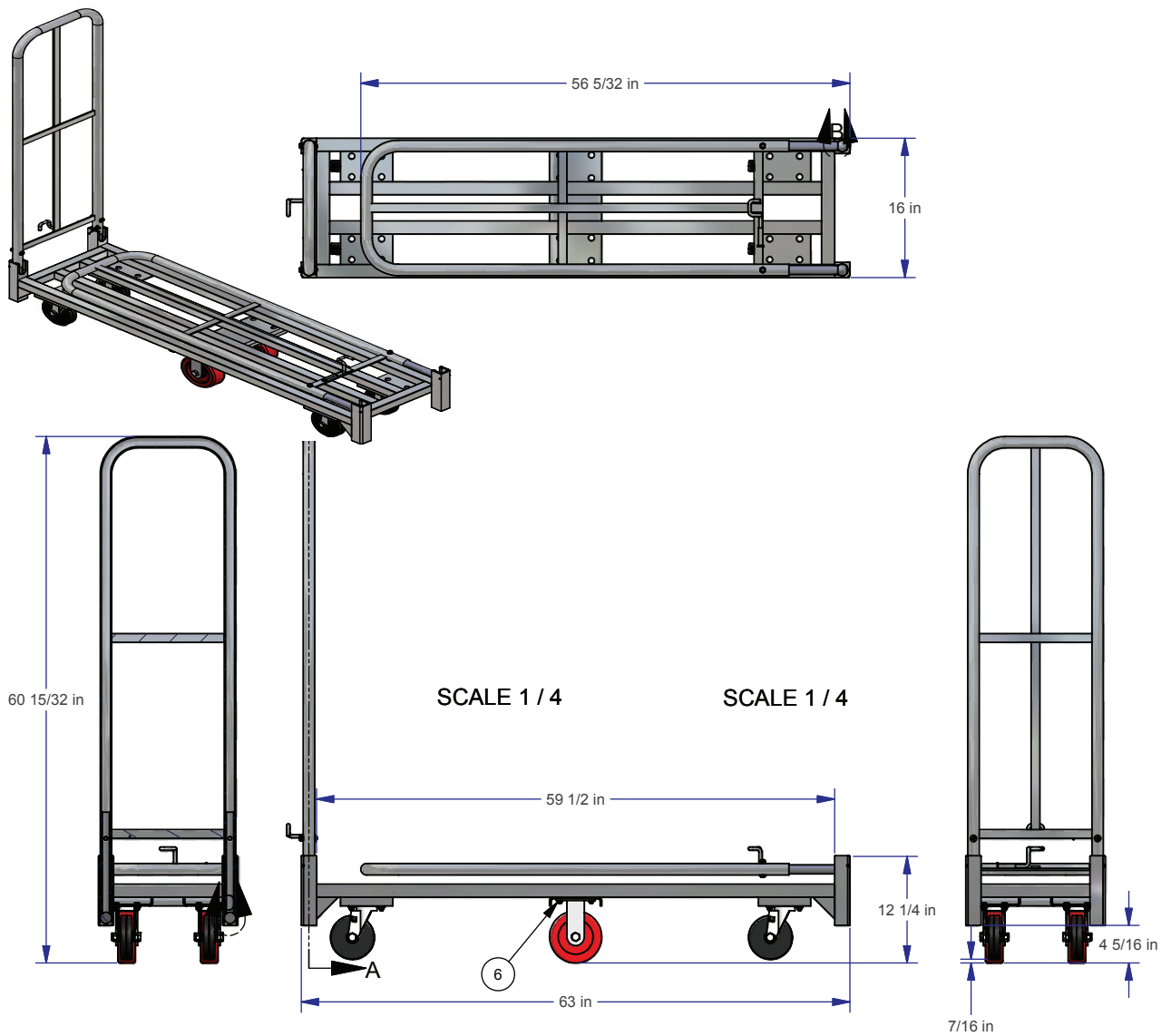

Winholt Equipment | 141 Eileen Way | Syosset, New York 11791
Pennsylvania Texas California India China

800.444.3595 | 516.921.0538 fax | www.winholt.com