



BEVERAGE-AIR

Project: _____

AIA#

Item: _____

Location: _____

SIS#

Approved: _____

WTFCS COOKSTAND FREEZER

WTFCS36-1 36" Worktop Freezer with Two Drawers

MODEL:

WTFCS36-1

WTFCS36-1 Freezer with 2 Drawers: Worktop Series

3 Year Parts/Labor Warranty
Additional 2 Year Compressor Warranty

CABINET CONSTRUCTION



WTFCS36-1

- Stainless steel front, sides, drawers and grille (galvanized back & bottom)
- Full electronic control
- 36" Worktop
- Drawers provide ample food product storage
- Full marine drip-guard to prevent spills from dripping over the edge
- Interior liner is made of corrosion resistant aluminum
- Dynamic load rating of 275 lbs per drawer
- 12 gauge drawer slides with 3 Delrin encased stainless steel roller bearings per each drawer slides - *LIFETIME WARRANTY ON ALL DRAWERS AND SLIDES*
- Heavy duty, fire-proof, reinforced insulated 16 gauge top
- Accommodates 6" deep pans in top & bottom drawers
- Self-closing feature engages in the last 1-2" of travel
- 6" Casters, 2 with brakes standard
- Freezer temperature operates at 0°F and below

OPTIONS & ACCESSORIES

- 6" Legs
- 3" Casters
- Gasket guards
- Worktop size option
- Flat top option
- Remote option

REFRIGERATION SYSTEM

- Refrigeration system uses R404a refrigerant to comply with all environmental concerns
- Automatic, electric defrost
- Epoxy coated evaporator coil



3779 Champion Blvd., Winston-Salem, NC 27105
1-888-845-9800 Fax: 1-336-245-6453
Beverage-Air.com sales@bevair.com



BEVERAGE-AIR

Worktop Freezer – With 2 Drawers

Models: WTFCS36-1

MODEL	WTFCS36-1
EXTERNAL DIMENSIONAL DATA	
Width Overall	36"
Depth Overall	34 3/4"
Height Overall with 6" Casters	26 5/8"
Number of Drawers	2
Depth with Drawer Extended	59 3/4"
Clear Drawer Opening (in)	22 5/8" x 6 1/2"
INTERNAL DIMENSIONAL DATA	
NET Capacity (cubic ft.)	5.67
Internal Width Overall (in)	23"
Internal Depth Overall (in)	26"
Internal Height Overall (in)	16 3/8"
ELECTRICAL DATA	
Full Load Amperes 115/60/2	5.0
ELECTRICAL DATA	
Horsepower	1/2
Capacity (BTU/Hr)*	1132
WEIGHT DATA	
Gross Weight (Crated lbs)	336 lbs
Height - Crated	26"
Width - Crated	39"
Depth - Crated	38"

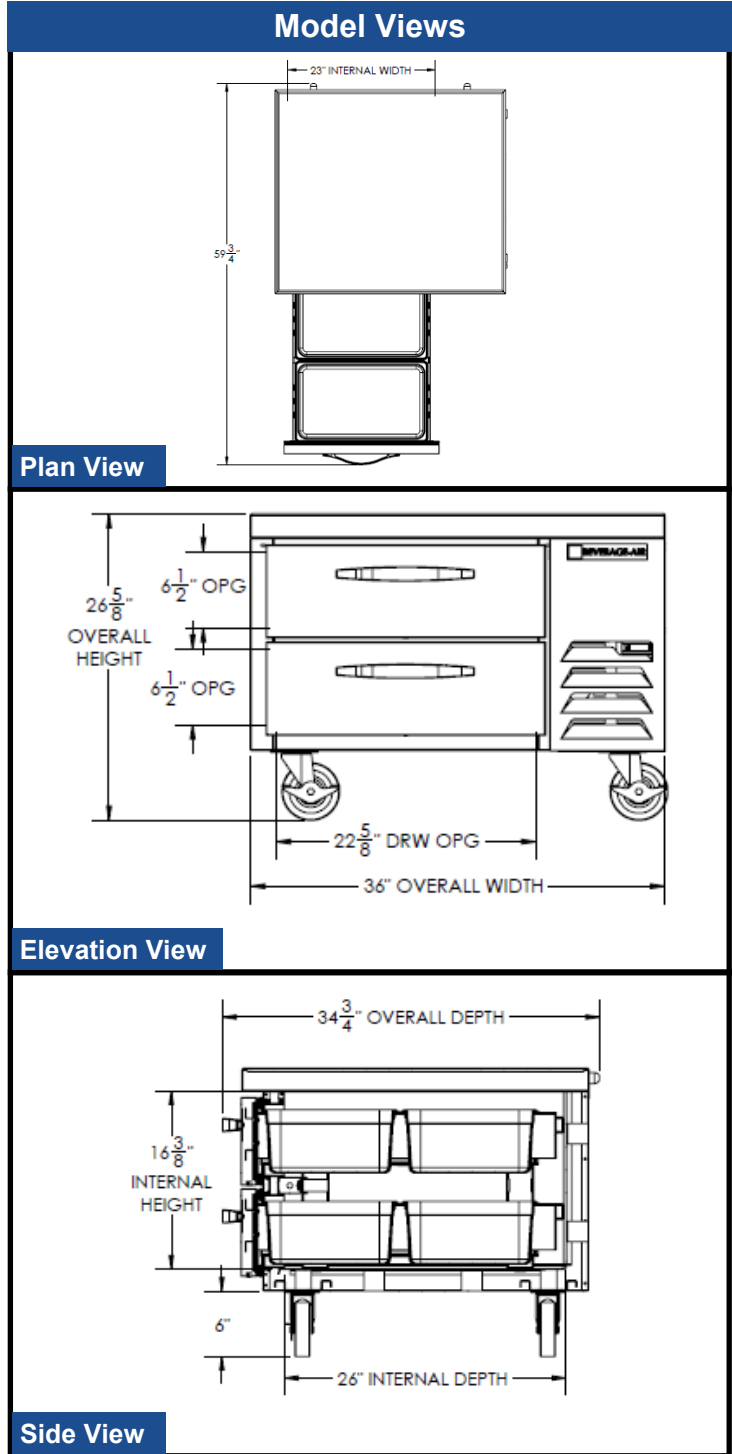
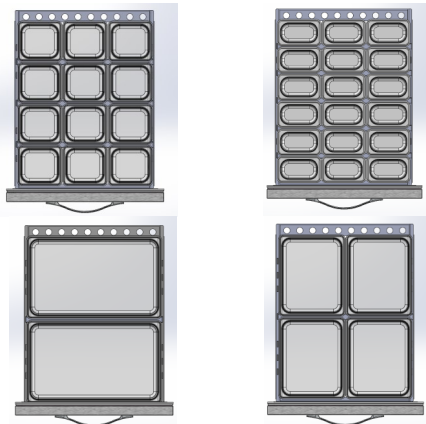

ELECTRICAL CONNECTION



115/60/1
NEMA-5-15P

Units pre-wired at factory and include 8' long cord and plug set.



an Ali Group Company



The Spirit of Excellence

3779 Champion Blvd., Winston-Salem, NC 27105
1-888-845-9800 Fax: 1-336-245-6453
Beverage-Air.com sales@bevair.com