

INSTRUCTIONS

AM16 DISHWASHERS



MODELS

AM16 - BAS
AM16T - BAS

AM16VL - BAS
AM16VLT - BAS

AM16 - ASR
AM16T - ASR

AM16VL - ADV
AM16VLT - ADV

AM16 - SVLT

AM16 - SCB

AM16VL - SCB



HOBART

701 S. RIDGE AVENUE
TROY, OHIO 45374-0001

937 332-3000

www.hobartcorp.com

FORM 41173 (June 2021)

Model AM16-BAS



Model AM16T-BAS



Model AM16VL-BAS



Model AM16VLT-BAS



Model AM16-ASR



Model AM16T-ASR



Model AM16VL-ADV



Model AM16VLT-ADV



TABLE OF CONTENTS

GENERAL	4
INSTALLATION	5
Unpacking	5
Installation Codes	5
Location	6
Corner Installation	7
Plumbing Connections	8
Water Requirements	8
Water Supply Connection	9
Drain Connection	10
Venting Requirements	11
Rate of Exhaust Flow Calculations	11
Table A: Heat Dissipation	12
Electrical Connections	12
Voltage Adjustment (380 - 415 Volt Machines Only)	14
Motor Rotation (480-Volt & 50-Hertz Machines Only)	14
Equipment Connections	15
Vent Fan Control	15
Hobart Supplied Detergent, Rinse Aid, and Sanitizer Dispenser Installation	15
Chemical Pump Programming (For Machines Equipped with Hobart Chemical Pumps)	15
Chemical Pump Priming	16
Testing Sanitizer (Chemical Sanitizing Machines)	17
Detergent and Rinse Aid Dispensers (For Machines with Chemical Pumps Supplied by Others)	17
Tubing Installation	17
Detergent Dispenser	18
Rinse Aid Dispenser	18
Detergent, Rinse Aid, Sanitizer Dispensers — Equipment Connections	19
Detergent Dispenser	19
Rinse Aid / Sanitizer Dispenser(s)	20
OPERATION	21
Preparation	21
Dishwashing	23
Recommended Condense Time (Based on Incoming Water Temp.)	24
CLEANING	26
Delime Instructions	26
Manual Delime Process (Models AM16-BAS, AM16T-BAS, AM16VL-BAS, AM16VLT-BAS, AM16-SCB, and AM16VL-SCB)	26
Auto Delime Process (Models AM16-ASR, AM16T-ASR, AM16VL-ADV, AM16VLT-ADV and AM16-SVLT)	27
Dos and Don'ts for Your New Hobart Warewasher	28
Manager Menu	28
Manager Menu Parameters	29
Hobart SmartConnect App	31
Getting Connected	31
MAINTENANCE	33
Wash Arms	33
Motor(s)	33
Chemical Pumps	33
Cleaning Baffles on AM16VLT-BAS, AM16VLT-ADV and AM16-SVLT Models	33
TROUBLESHOOTING	35
Error Code Chart with Possible Solutions	35
Communication Module	39
SERVICE	41
AM16 Expendable Parts	41

Installation, Operation and Care Of AM16 DISHWASHERS SAVE THESE INSTRUCTIONS

GENERAL

Models AM16-BAS, AM16T-BAS, AM16VL-BAS, AM16VLT-BAS, AM16-ASR, AM16T-ASR, AM16VL-ADV, AM16VLT-ADV, AM16-SVLT, AM16-SCB, AM16VL-SCB dishwashers can be configured for both straight through or corner operation. AM16-BAS, AM16T-BAS, AM16VL-BAS, AM16VLT-BAS, AM16-ASR, AM16T-ASR, AM16VL-ADV, AM16VLT-ADV, AM16-SVLT, AM16-SCB, AM16VL-SCB dishwashers are shipped from the factory in straight through configuration. Straight through machines can be easily converted to corner operation.

The AM16-BAS, AM16T-BAS, AM16VL-BAS, AM16VLT-BAS, AM16-ASR, AM16T-ASR, AM16VL-ADV, AM16VLT-ADV, AM16-SVLT dishwashers are designed to operate in hot water sanitizing mode only (Designated by the NSF temperature requirements of 150°F Wash and 180°F Rinse. These temperatures can be found on the label located under the touchscreen controls on the lower part of the machine).

The AM16-SCB, AM16VL-SCB dishwashers are designed to operate in chemical sanitizing mode only (Designated by the NSF temperature requirements of 120°F Wash and 120°F Rinse. These temperatures can be found on the label located under the touchscreen controls on the lower part of the machine).

The serial number can be found on the machine data label located at the bottom of the front right leg of the machine.

Hobart supplied chemical pumps ship standard with all AM16-SVLT, AM16-SCB and AM16VL-SCB models. Chemical pumps are available as an accessory kit (field installed) for all other models or contact your chemical representative for a chemical feeder system to be supplied and installed by others.

The wash pump motor is rated 2 H.P. and has thermal overload protection.

The fill line incorporates an air gap on all models to prevent any reverse flow of water from the dishwasher into the potable water supply. The unit, once turned on, fills the wash tank to the appropriate level and automatically stops filling once the level is reached. A pressure transducer reads the water level in the wash tank and shuts off the heat supply if the water level becomes too low. When the water returns to the proper level, the heating circuit becomes operational again.

An automatic pumped drain and pumped rinse system are standard on all models.

A frame mounted 7.1kW electric booster water heater is equipped on all hot water sanitizing models. The booster water heater is designed to maintain a minimum final rinse temperature of 180°F provided the incoming water is at least 110°F. For ventless models AM16VL-BAS, AM16VLT-BAS, AM16VL-ADV, AM16VLT-ADV and AM16-SVLT, the booster water heater is designed to maintain a minimum final rinse temperature of 180°F with cold incoming water of at least 55°F.

Models AM16-SCB and AM16VL-SCB are provided with a 4.3kW electric booster water heater. The booster water heater is designed to maintain a minimum final rinse temperature of 120°F provided the incoming water is at least 90°F (120°F recommended).

Ventless Models AM16VL-BAS, AM16VLT-BAS, AM16VL-ADV, AM16VLT-ADV and AM16VL-SCB do not require a vent hood. They use an internal condensing system to minimize the water vapor escaping from the unit during loading and unloading. High-temperature AM16-BAS, AM16T-BAS, AM16-ASR, AM16T-ASR models typically require a hood or vent over the dishwasher to meet local codes. Low-temperature chemical sanitizing machines or low usage electric heat dishwashers may not require individual venting of the machine if the

room is amply exhausted. Refer to pages 11 - 12 for venting and hood requirements. Verify with local code officials for final determination.

Models AM16-ASR, AM16T-ASR, AM16VL-ADV, AM16VLT-ADV and AM16-SVLT are equipped with an Automatic Soil Removal (ASR) system. The ASR system automatically redirects food soil left over after pre-scraping to an external scrap basket located at the right side of the machine (accessory available for left hand installation). This helps to keep the wash water cleaner, reducing the frequency of water changes. This saves water, energy, and chemicals. The AM16-ASR-Series machines are only available in hot water sanitizing mode.

Models AM16VL-ADV, AM16VLT-ADV and AM16-SVLT require a single cold-water supply and come equipped with a drain water energy recovery system which includes drain water tempering. They utilize a heat exchanger to capture the energy from the drain water and preheat the incoming cold water for the final rinse. The AM16VL-ADV, AM16VLT-ADV and AM16-SVLT are also equipped with an ASR system.

INSTALLATION

UNPACKING

Immediately after unpacking the dishwasher, check for possible shipping damage. If this machine is found to be damaged, save the packaging material and contact the carrier within 5 days of delivery.

NOTE: Use caution when using a forklift to remove machine from skid. DO NOT use door lift handle to move machine, as it will cause door lift issues.

Prior to installation, test the electrical service to ensure it agrees with the specifications on the machine data plate. The dishwasher data plate is located at the lower right hand corner of the machine.

INSTALLATION CODES

Installation must be in accordance with state and local codes and the National Electrical Code ANSI/NFPA70 (latest edition). In Canada, the installation code is CSA 22.1 (latest edition).

LOCATION

Before finalizing the location, make sure that consideration has been given for the electrical conduit, water supply, drain connection, venting (if applicable), tabling (if needed), chemical feeder replenishment (if applicable) and adequate clearance for opening the door.

The dishwasher must be level before any connections are made. Turn the threaded feet (Fig. 1) as required to level the machine and adjust to the desired height.

The edge of dish table that overhangs the AM16 wash tank should be turned down and fitted over the top of the dishwasher tank (Fig. 2). Apply an NSF approved sealant between the overhang of the dish table and the inner wall of the wash tank to prevent leakage (Fig. 2). Fasten the dish tables to the inner wall of the wash tank with non-rusting truss head screws or rivets (Fig. 2).

For straight-through installations, 30" clearance at the front and 15" clearance at the right side by 29-1/2" clearance above the finished floor must be provided for service.

For machines equipped with ASR, 30" clearance at the front and 24" clearance at the right side (or left if ASR is relocated to left side) by 33" clearance above the finished floor must be provided for service. If ASR is relocated to left side, then 15" clearance is required at right side.

NOTE: For 480-volt units, 20" clearance required at left side.

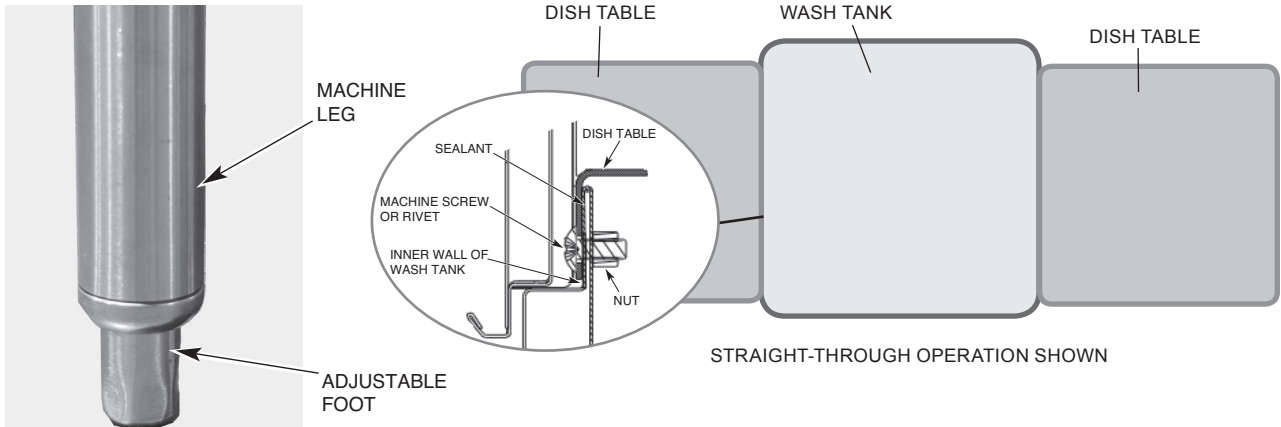

Fig. 1

Fig. 2

Based on dish table design, rear table brackets (Fig. 3) may need to be adjusted or removed. Loosen the two bolts and nuts and adjust or remove as required.



Fig. 3

NOTE: For AM16-ASR, AM16T-ASR, AM16VL-ADV, AM16VLT-ADV and AM16-SVLT models, the ASR module may be relocated to the left side of the machine using service kit part number 00-950446 or sales accessory kit ASRLEFTKIT-AM16.

CORNER INSTALLATION

Before placing the dishwasher in its operating location, check machine configuration. If the machine is being installed in a corner (Figs. 4, 5), clearances of 30" out from the dishwasher under the left-hand tabling by 29-1/2" above the finished floor and 15 inches out from the dishwasher at the right side by 29-1/2" above the finished floor must be provided for servicing. For proper installation of a corner machine, the control and display should be positioned at the front corner for operator access (Fig. 5).

For corner installations, reposition the rack guide to the left side of the rack track using the following procedure (Fig. 6).

1. Remove two nuts and bolts securing front rack guide to rack track and remove rack guide.
2. Position rack guide on left side of rack track aligning holes in rack guide to spacers on rack track.
3. Secure using hardware removed in Step 1. Note: Nuts should be installed on the inside of the rack track.

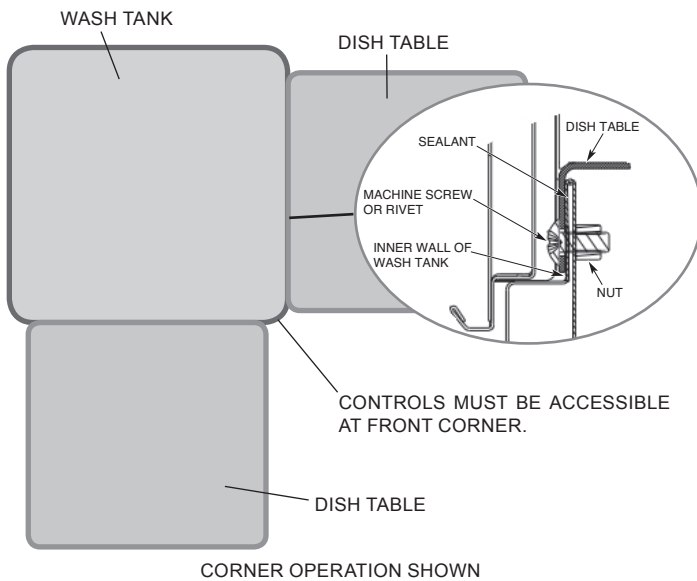

Fig. 4

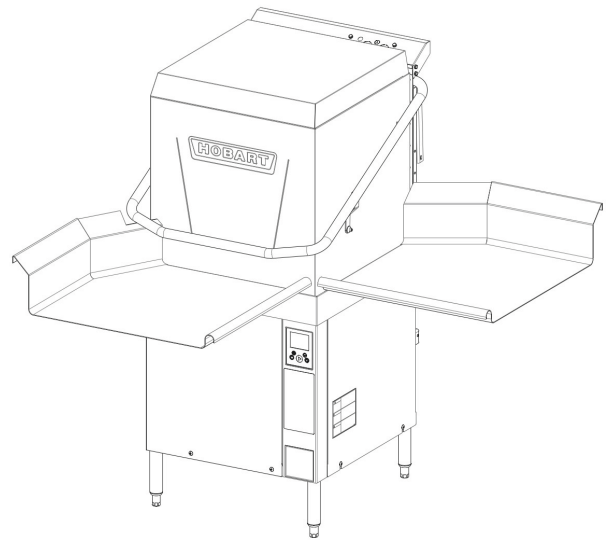

Fig. 5

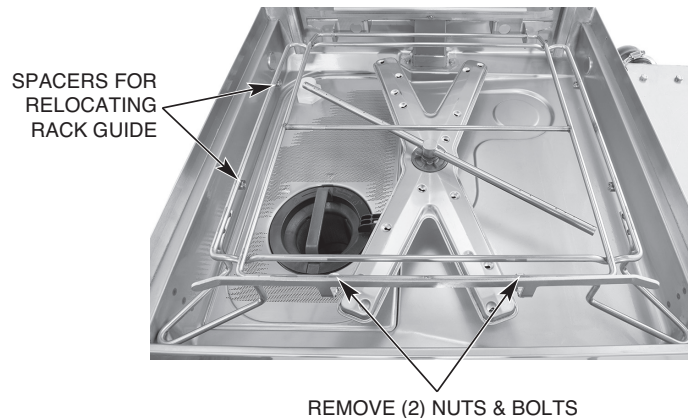
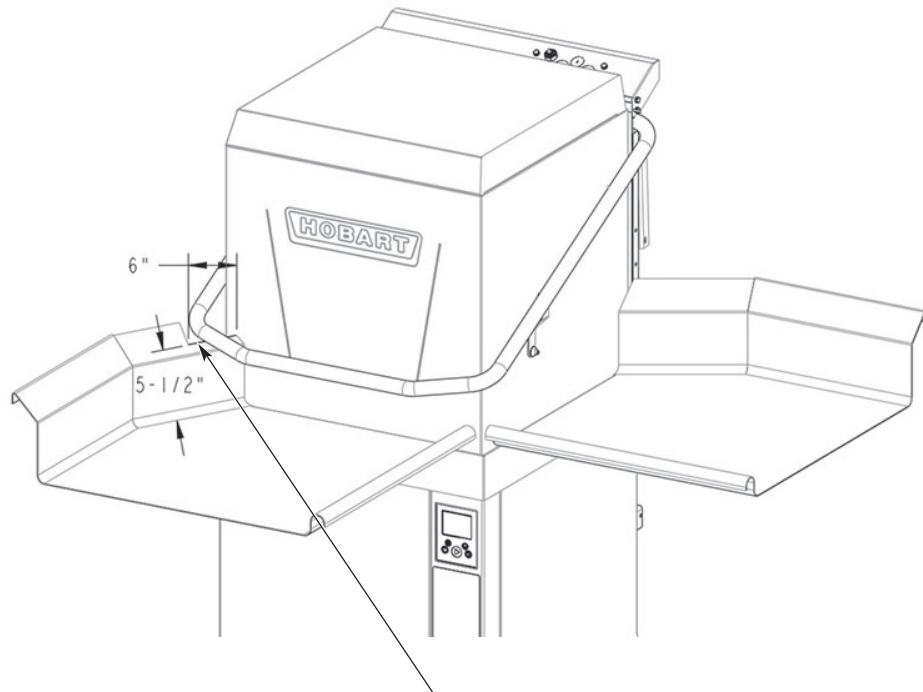

Fig. 6

A splash shield kit is available (at extra cost) for corner installations to prevent excessive splashing on wall. Order sales accessory CORNER-INST-AM16 or service kit part number 00-562156-00001. For installation, refer to 0F-45885 installation instructions supplied with kit.

For corner installations, tabling with backsplashes over 5-1/2" high require that a notch be provided to prevent interference with the door handle (Fig. 7).



A NOTCH MUST BE ADDED TO BACKSPASHES OVER 5-1/2" HIGH ON CORNER MACHINES TO PREVENT INTERFERENCE WITH DOOR HANDLE. NOTCH MUST EXTEND 6" FROM FACE OF THE MACHINE.

Fig. 7

PLUMBING CONNECTIONS

⚠ WARNING Plumbing connections must comply with applicable sanitary, safety and plumbing codes.

Water Requirements

Proper water quality can improve ware washing performance by reducing spotting, enhancing effectiveness of labor and extending equipment life. Water conditions vary from one location to another. The recommended proper water treatment for effective and efficient use of this equipment will also vary depending on the local water conditions. Ask your municipal water supplier for details about local water conditions prior to installation.

Recommended water hardness is 3 grains of hardness per gallon or less. Higher hardness may cause excessive formation of lime scale. Water hardness above 3 grains per gallon requires water treatment. Water treatment has been shown to reduce costs associated with machine cleaning, reduce deliming of the dishwasher and reduce detergent usage in the dishwasher. Chlorides must not exceed 50 ppm.

NOTICE High iron levels in the water supply can cause staining and may require an iron filter. High chloride levels in the water supply can cause pitting and may require a chloride removal system. Contact your local water treatment professional for proper water treatment.

Sediment may require a particulate filter. Dissolved solids may require water treatment such as a water softener, reverse osmosis system, etc. Contact your local water treatment professional for proper water treatment.

If an inspection of the dishwasher or booster heater reveals lime build-up after the equipment has been in service, water treatment is recommended. If a water softener is already in place, ensure there is a sufficient level of salt. Contact your Hobart Service office for specific recommendations.

Water Supply Connection

The plumber connecting this machine is responsible for making certain that water lines are THOROUGHLY FLUSHED OUT BEFORE connecting to the dishwasher. This "flush-out" is necessary to remove all foreign matter, such as chips (resulting from cutting or threading of pipes) pipe joint compound from the lines; or, if soldered fittings are used, bits of solder or cuttings from the tubing. Debris, if not removed, may lodge in the dishwasher's plumbing components and render them inoperative. Manual valves or solenoid valves fouled by foreign matter and any expenses resulting from this fouling are NOT the responsibility of the manufacturer and associated repair costs are not covered under warranty.

Water supply requirements are as follows:

WATER SUPPLY REQUIREMENTS

Model	Sanitizing Mode	Connection	Water Supply		
			Minimum	Maximum	Recommended
AM16-BAS AM16T-BAS	Hot Water Sanitizing	Hot Water	110°F (43°C)	N/A	140°F (60°C)
AM16-ASR AM16T-ASR	Hot Water Sanitizing	Hot Water	110°F (43°C)	N/A	140°F (60°C)
		Cold Water	55°F (13°C)	90°F (32°C)	65°F (18°C)
AM16VL-BAS AM16VLT-BAS AM16VL-ADV AM16VLT-ADV AM16-SVLT	Hot Water Sanitizing	Cold Water	55°F (13°C)	90°F (32°C)	65°F (18°C)
AM16-SCB	Chemical Sanitizing	Hot Water	120°F (49°C)	N/A	140°F (60°C)
AM16VL-SCB	Chemical Sanitizing	Hot Water	120°F (49°C)	N/A	140°F (60°C)
		Cold Water	55°F (13°C)	90°F (32°C)	65°F (18°C)

AM16-ASR, AM16T-ASR and AM16VL-SCB models require both a cold water supply and a hot water supply.

NOTICE On AM16VL-BAS, AM16VLT-BAS, AM16VL-ADV, AM16VLT-ADV, AM16-SVLT and AM16VL-SCB installations, the cold water supply must not exceed 90° F (32° C) for proper operation. Optimal results are obtained when cold water supply temperature is below 65° F (18° C). For best results, it may necessary to use 1/2" pipe for cold water pipe size and minimize the distance between the dishwasher and the entrance into the building. Pipe insulation will also improve results.

If cold water supply temperature is consistently above 90° F (32° C) or if excessive water vapor or steam is entering the dish room after the condensing cycle is complete, contact Hobart Service to increase condensing time.

Required flowing water pressure to the dishmachine is 15 – 65 PSIG. If flowing pressures higher than 65 PSIG are present, a pressure regulating valve must be installed in the water line to the dishmachine (by others). If flowing pressure is less than 15 psi, improper machine operation may result. All AM16 models are equipped with a pumped rinse system; therefore, a water pressure gauge is not required and is not supplied with the machine.

NOTICE The water pressure regulator must have a relief bypass. Failure to use the proper type of pressure regulator may result in damage to the unit.

A manual shutoff valve (not supplied) should be installed upstream of the fill hose to accommodate servicing the machine. It is recommended that a line strainer (not supplied) be installed in the supply line between the manual shutoff valve (not supplied) and the connection point on the machine.

All machines ship standard with a 96" long stainless steel braided fill hose with a 3/4" female garden hose fitting. A second fill hose is shipped for machines equipped with both hot and cold water connections. Make plumbing connections with 1/2" minimum copper piping OD (3/4" recommended), with a 3/4" male garden hose fitting (not supplied).

Drain Connection

A drain hose, 5/8" inside diameter and 6' long, is provided with machine. This should be securely plumbed into a drain. Use care not to kink the hose. Drain must have a minimum flow capacity of 14.5 gallons per minute. The drain hose height cannot exceed 40" above finished floor.

If a grease trap is required by code, it should have a minimum flow capacity of 14.5 gallons per minute.

If machine is equipped with ASR, use supplied pumped drain air gap kit (part # 00-562723-00001) shipped with machine; refer to installation instructions included with kit. For -BAS and VL-BAS models, pumped drain air gap kit is available through sales using accessory code PMP-DRAIN-AM16 or service kit part # 00-562723-00002.

NOTE: If machine is equipped with ASR, DO NOT plumb ASR drain line to 3-comp sink drain.

VENTING REQUIREMENTS

NOTE: Any listed and labeled factory-built commercial exhaust hood tested in accordance with UL Standard 710 by a nationally recognized testing laboratory, must be installed according to the terms of its listing and the manufacturer's installation instructions.

Rate of Exhaust Flow Calculations

Based on the 2018 International Mechanical Code.

The minimum net airflow for Type II hoods used for dishwashing appliances shall be 100 cfm per linear foot of hood length. The net quantity of exhaust air shall be calculated by subtracting any airflow supplied directly to a hood cavity from the total exhaust flow rate of a hood.

Ventless models AM16VL-BAS, AM16VLT-BAS, AM16-SVLT, AM16VL-ADV, AM16VLT-ADV and AM16SVL-SCB do not require a Type II vent hood. According to 507.3 of the 2018 IMC, Type II hoods are not required where the heat and moisture load is incorporated into the HVAC system design. See Table A (page 12) for heat dissipation or heat gain to space.

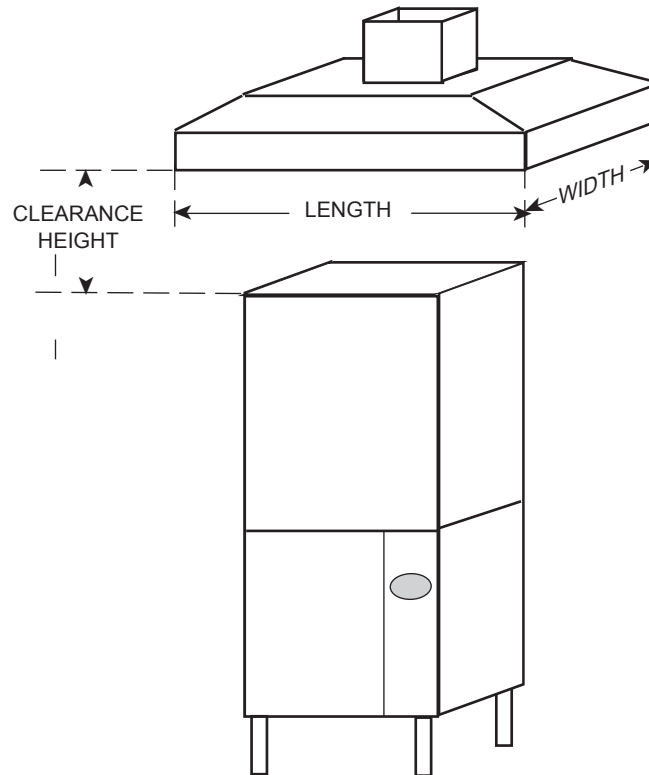

Fig. 8

TABLE A: HEAT DISSIPATION

	Model	Electric Heat	Electric Booster	Latent Heat (BTU/HR)	Sensible Heat (BTU/HR)
Hot Water Sanitizing	AM16-BAS	X	X	7,800	4,000
	AM16T-BAS	X	X	12,300	5,700
	AM16VL-BAS	X	X	4,300	3,500
	AM16VLT-BAS	X	X	6,800	5,000
	AM16-ASR	X	X	7,800	4,000
	AM16T-ASR	X	X	12,300	5,700
	AM16VL-ADV	X	X	3,200	3,700
	AM16VLT-ADV	X	X	5,100	5,300
	AM16-SVLT	X	X	5,100	5,300
Chemical Sanitizing	AM16-SCB	X	X	3,570	6,700
	AM16VL-SCB	X	X	3,600	4,200

- Assumptions:
1. Machines operate 70% of each hour while in use.
 2. Values shown are heat that enters room.
 3. 70% of heat output is latent, 30% is sensible.

ELECTRICAL CONNECTIONS

⚠ WARNING Electrical and grounding connections must comply with the applicable portions of the National Electrical Code, NFPA 70 (latest edition) and / or other local electrical codes.

⚠ WARNING Disconnect the electrical power to the machine (both dishwasher and booster if applicable) and follow lockout / tagout procedures. Be sure all circuits are disconnected.

Refer to the wiring diagram attached inside the right hand trim panel and to the machine data plate for service size requirements when connecting the dishwasher. Also, refer to Electrical Data, shown below.

To access the controls area, remove the right side panel and open the control panel door. The dishwasher electrical service connection can be made at the 3/4" or 1" trade size knock out hole located on the right side at the rear of the machine.

ELECTRICAL DATA

Models	Volts / Hz / Ph	Tank Heat	Minimum Circuit Ampacity Maximum Protective Device AMPS		
			TB1	TB2	Standard Single Point Electrical Connection Dishwasher and Booster (3 Phase Only)
AM16-BAS, AM16T-BAS, AM16VL-BAS, AM16VLT-BAS, AM16-ASR, AM16T-ASR, AM16VL-ADV, AM16VLT-ADV, AM16-SVLT	208 - 240 / 60 / 1	Electric	50	50	
	208 - 240 / 60 / 3	Electric	30	30	60
AM16-BAS, AM16T-BAS, AM16VL-BAS, AM16VLT-BAS	480 / 60 / 3	Electric	15	15	30
AM16-BAS, AM16T-BAS	200 - 240 / 50 / 3	Electric	30	30	60
	380 - 415 / 50 / 3	Electric	20	20	30
					Standard Single Point Electrical Connection with 4.3 KW Electric Booster
AM16-SCB, AM16VL-SCB	208 / 240 / 60 / 1	Electric			30 - 40 / 35 - 45

Compiled in accordance with the national electrical code, NFPA 70 (latest edition).

A fused disconnect switch or circuit breaker (customer supplied) must be installed in the electrical service line(s) supplying this dishwasher and should meet the requirements of your local electrical code.

All AM16 models, except for the AM16-SCB and AM16VL-SCB models, ship standard with a 3-phase voltage supply and a single point electric configuration. The standard single point electric supply connects to terminal block TB1 in the controls area (Fig. 9). The machine must be grounded according to electrical code(s); a grounding lug is provided.

The AM16-SCB and AM16VL-SCB models ship standard with a single-phase voltage supply and a single point electric configuration. The standard single point electric supply connects to terminal block TB1 in the controls area (Fig. 9). The machine must be grounded according to electrical code(s); a grounding lug is provided.



Fig. 9

To convert an AM16 model to a dual point electric configuration or to convert from 3-phase to single phase, refer to F-45845 instructions attached inside right hand trim panel of machine.

NOTE: AM16-SCB and AM16VL-SCB models cannot be field converted to a dual point configuration. These models can only be installed with a single-phase, single point electric connection configuration.

Voltage Adjustment (380 - 415 Volt Machines Only)

This adjustment procedure applies to all AM16 dishwashers rated at 380 to 415 volts, 50 Hz, 3 phase. All other AM16 dishwasher voltages are preset at the factory and do not require this adjustment procedure.

THIS PROCEDURE MUST BE DONE ONLY BY A QUALIFIED ELECTRICIAN.

If the supply voltage to the machine is 415 volts, no change is necessary. The control circuit transformer [T2] should already be set to operate at 415 volts.

If the supply voltage to the machine is 380 volts, the control circuit transformer [T2] must be changed to operate at 380 volts. To change the tap, relocate the red wire on TB5 terminal block from the 415V tap to the 380V tap.

NOTE: TB5 is located on the controls baseplate located at the lower right side of the machine (Fig. 10).

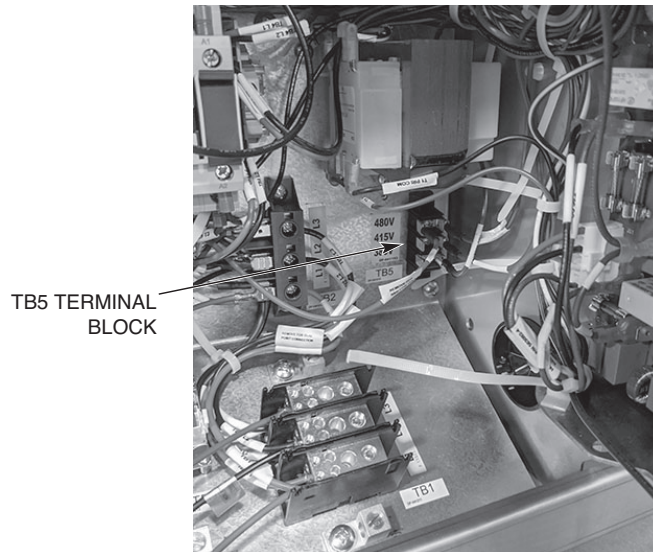

Fig. 10

Motor Rotation (480-Volt & 50-Hertz Machines Only)

Before placing machine into service, check wash pump motor for correct rotation by observing motor direction. If pump motor does not rotate in the correct direction, **DISCONNECT ELECTRICAL POWER SUPPLY** and interchange any two of the incoming power supply leads. Reconnect the power supply and verify correct rotation.

EQUIPMENT CONNECTIONS

⚠ WARNING Electrical and grounding connections must comply with the applicable portions of the National Electrical Code, NFPA 70 (latest edition) and / or other local electrical codes.

⚠ WARNING Disconnect the electrical power to the machine (both dishwasher and booster if applicable) and follow lockout / tagout procedures. Be sure all circuits are disconnected.

Vent Fan Control

The vent fan control feature is standard on all non-ventless AM16 models. The vent fan control relay provides switch contacts only and does not provide power to the vent fan motor. The rating for the vent fan control relay connected to terminals VFC1 and VFC2 is 1.5 amps at nameplate supply voltage. When the dishwasher is connected to the vent fan, the vent fan is switched on when the dishwasher is on and off when the dishwasher is off.

HOBART SUPPLIED DETERGENT, RINSE AID AND SANITIZER DISPENSER INSTALLATION

All AM16-SCB, AM16VL-SCB and AM16-SVLT models ship standard with chemical pumps. Chemical pumps are available as an accessory kit for all other models. For standard height machines, order sales accessory code CHEMPUMP-STD-AM16 or service part # 00-563068-00002. For tall machines, order sales accessory code CHEMPUMP-HTS-AM16 or service part # 00-563069. For all machines equipped with the Hobart chemical pumps, refer to 0F-45893 Installation Instructions shipped with the machine or in the accessory kit.

Chemical Pump Programming (For Machines Equipped with Hobart Chemical Pumps)

NOTE: The Chemical Dispensing Module is factory preset to the following settings. This adjustment procedure is to verify or alter settings if chemical dosing changes are required to achieve proper concentrations.

1. Power on dishwasher. Display shows ready screen when fill cycle has completed.
2. Press 'Menu' button.
3. With 'Manager Menu' highlighted, press the 'Enter' button. The 'Enter PIN' screen will be displayed.
4. The default manager code is 1001. Use the arrow buttons to change the value and then press the 'Enter' button to select the value and toggle to the next digit until the code is entered.
5. After pressing 'Enter' for the last digit, use the down arrow and scroll until 'chemical menu' is outlined. Press Enter.
6. Below is a list of the editable parameters and the Hobart factory settings for the built-in Hobart chemical pumps. Use the Up and Down Arrows to toggle to the next Parameter.
 - a. To change a parameter value, press the Enter button once the parameter is outlined.
 - b. Press the Up and Down Arrows to change the parameter value.
 - c. Once the required parameter value is displayed, press the 'Enter' button to save the selection.
7. To exit the programming, use the Up and Down Arrows to scroll thru the parameters until 'back' is outlined and press the 'Enter' button. Repeat this procedure until the Ready screen is displayed.

AM16 Detergent Factory Settings

Parameter Name	Kay QSR Yellow	Keystone	Super Trump	Ultra Klene
Concentration (%)	0.2 - 0.25%	0.08 - 0.11%	0.16%	0.08 - 0.11%
Min Concentration (mL/L)	2.00 ml/L	1.10 ml/L	1.60 ml/L	0.80 ml/L
Chemical Volume per Cycle	5.00 ml	2.75 ml	4.00 ml	2.00 ml
Pump Speed	100%			
Pump On-time	2.50 s	1.38 s	1.86 s	0.93 s
Pump Revolutions	5.96	3.28	4.43	2.22

AM16 Rinse Aid Factory Settings

Parameter Name	Esteem Dry All	EcoTemp Ultra Dry	Keystone Rinse Aid	EcoLab RO Free RA	EcoLab Rinse Dry
Concentration (%)	0.013 - 0.053%	0.0132 - 0.0311%	0.0132 - 0.0311%	0.0176 - 0.044%	0.0132 - 0.022%
Min Concentration (mL/L)	0.65 ml/L	0.13 ml/L	0.13 ml/L	0.18 ml/L	0.13 ml/L
Chemical Volume per Cycle	1.63 ml	0.33 ml	0.33 ml	0.44 ml	0.33 ml
Pump Speed	100%				
Pump On-time	0.76 s	0.15 s	0.15 s	0.20 s	0.15 s
Pump Revolutions	1.80	0.37	0.37	0.49	0.37

AM16 Sanitizer Factory Settings

Parameter Name	Esteem Sani- NC	Eco-San	Luster
Concentration (%)	5.25%	8.40%	10.00%
Min Concentration (mL/L)	1.96 ml/L	1.20 ml/L	1.17 ml/L
Chemical Volume per Cycle	4.95 ml	3.05 ml	3.00 ml
Pump Speed	19%	10%	10%
Pump On-time	N/A		
Pump Revolutions			

Chemical Pump Priming

1. Power on dishwasher. Display shows ready screen when fill cycle has completed.
2. Press 'Menu' button.
3. With 'Manager Login' highlighted, press the 'Enter' button. The 'enter PIN' screen will be displayed.
4. The default manager code is 1001. Use the arrow buttons to change the value and then press the 'Enter' button to select the value and toggle to the next digit until the code is entered.

5. After pressing 'Enter' for the last digit, use the down arrow and scroll until 'chemical menu' is outlined. Press Enter.
6. Scroll down until 'Prime Chemical Pumps' is outlined. Press Enter.
7. 'priming suction hose detergent' is displayed. Use the arrow keys to select yes or no to prime the detergent pump. Press Enter button.
8. 'priming suction hose rinse aid' is displayed. Use the arrow keys to select yes or no to prime the rinse aid pump. Press Enter button.
9. 'priming suction hose sanitizer' is displayed. Use the arrow keys to select yes or no to prime the sanitizer pump. Press Enter button.
10. 'filling chemical hoses' is displayed and the appropriate chemical pump(s) set to 'yes' in Steps 7 - 9 will prime for 20 seconds and display will revert back to the 'chemical menu'.
11. To exit the menu, use the Up and Down Arrows to scroll thru the parameters until 'back' is outlined and press the 'Enter' button. Repeat this procedure until the Ready screen is displayed.

Testing Sanitizer (Chemical Sanitizing Machines)

1. Place a serving bowl or mixing bowl upside down on a rack and run it through a cycle.
2. After cycle, dip a sanitizer test strip into the water collected on the surface of the bowl.
3. Compare the test strip to the test scale provided with your testing kit (Fig. 11). If the sanitizer level is out of limits (i.e. below 50 ppm or above 100 ppm), adjust the dosing. Refer to Chemical Pump Programming (page 15), for adjustment instructions, or contact your chemical provider.

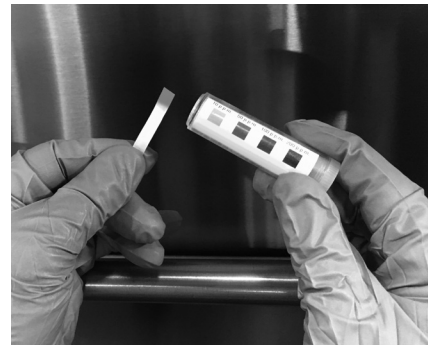

Fig. 11

DETERGENT AND RINSE AID DISPENSERS (FOR MACHINES WITH CHEMICAL PUMPS SUPPLIED BY OTHERS)

Tubing Installation

Detergent and rinse aid dispensers not provided by Hobart must have all connections sealed against leakage.

The AM16 Series dishwashers use 0.67 gallons of rinse water per rack at a flow rate of 4.02 gallons per minute. This information is used when setting the detergent and rinse aid pumps.

NOTE: All AM16 models utilize a pumped rinse system; pressure gauge is not required.

Detergent Dispenser

The dishwasher has three 7/8" diameter plugged holes; two on the rear upper tank side walls (one left side, one right side, Fig. 12) and one on the lower front part of the tank (Fig. 13). With the tank empty, remove both plugs to install the detergent dispenser.

- The upper tank holes are for installation of the detergent feeder tube (use left or right side location).
- The lower tank hole is used for installation of the detergent sensor.

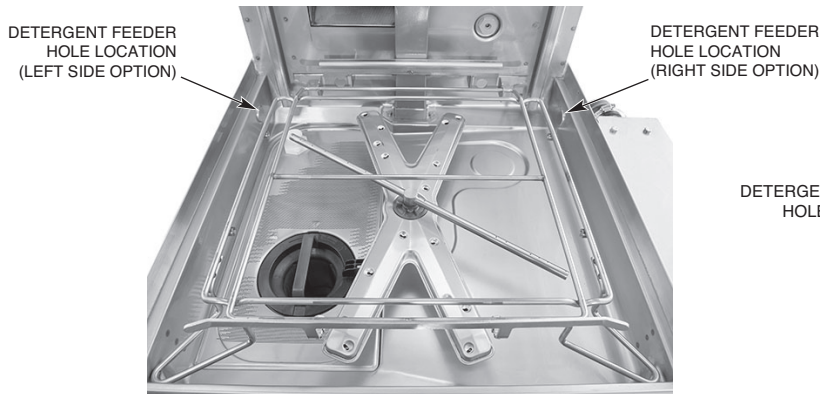

Fig. 12

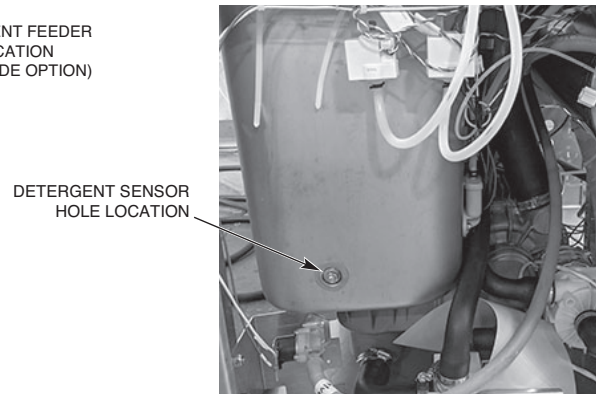

Fig. 13

Rinse Aid Dispenser

Remove the 1/8" NPT plug (Fig. 14 for standard height units, Fig. 15 for tall units) for installation of the rinse aid dispenser tube.



Fig. 14



Fig. 15

DETERGENT, RINSE AID, SANITIZER DISPENSERS — EQUIPMENT CONNECTIONS

⚠ WARNING Electrical and grounding connections must comply with the applicable portions of the National Electrical Code, NFPA 70 (latest edition) and / or other local electrical codes.

⚠ WARNING Disconnect the electrical power to the machine (both dishwasher and booster if applicable) and follow lockout / tagout procedures. Be sure all circuits are disconnected.

This machine must be operated with an automatic detergent feeder and, if applicable, an automatic chemical sanitizer feeder, including a visual means to verify that detergents and sanitizers are delivered or a visual or audible alarm to signal if detergents and sanitizers are not available for delivery to the respective washing and sanitizing systems. Refer to the installation section of this manual and to the chemical feeder equipment manual(s).

Detergent Dispenser

Terminals DPS1 and DPS2 (Fig. 16) are supplied with controlled machine line voltage. They are ON during the wash cycle and OFF between cycles, when machine is in delime cycle, or when the machine power supply is OFF. Maximum rating for detergent dispenser connected to DPS1 and DPS2 is 1.5 amps at line voltage. Check the machine supply voltage and use corresponding feeder transformer voltage. Use UL Listed 600 volt minimum insulated wire for the connections. Do not use bell wire, lamp cord or similar type wire. Splice connections, if required, must be made in the feeder transformer junction box (supplied by others) — not in the main controls enclosure. Use 7/8" diameter hole located at right rear corner of machine for 1/2" trade size conduit fitting. Remove the right side panel. Strain relief fittings must be provided for all wiring.

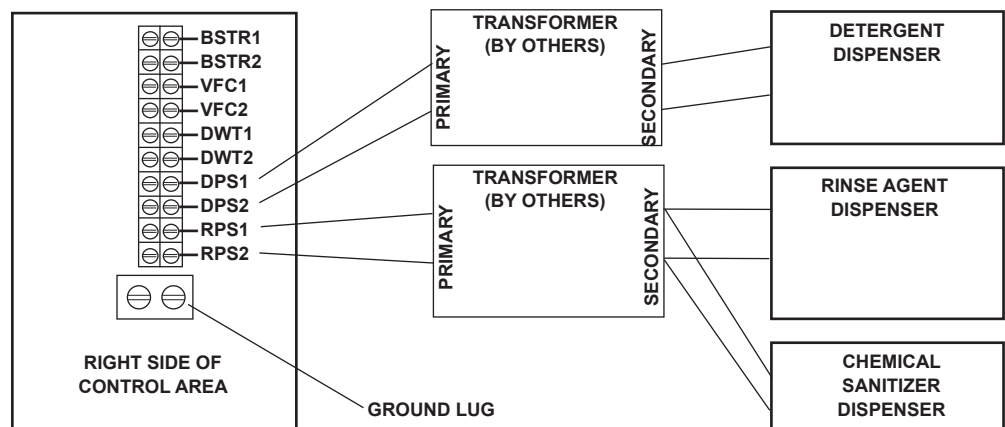

Fig. 16

Rinse Aid / Sanitizer Dispenser(s)

Terminals RPS1 and RPS2 (Fig. 16) are supplied with controlled machine line voltage. They are ON during the rinse cycle and OFF between cycles, when machine is in delime cycle, or when the machine power supply is OFF. Maximum rating for rinse aid dispenser connected to RPS1 and RPS2 is 1.5 amps at line voltage. Check the machine supply voltage and use corresponding feeder transformer voltage. Use UL Listed 600 volt minimum insulated wire for the connections. Do not use bell wire, lamp cord or similar type wire. Splice connections, if required, must be made in the feeder transformer junction box (supplied by others) — not in the main controls enclosure. Use 7/8" diameter hole located at right rear corner of machine for 1/2" trade size conduit fitting. Strain relief fittings must be provided for all wiring.

OPERATION

PREPARATION

The standpipe must be in its proper location below the strainer basket (Fig. 17). Place the strainer pan and the strainer basket in their proper positions (Fig. 18).



Fig. 17

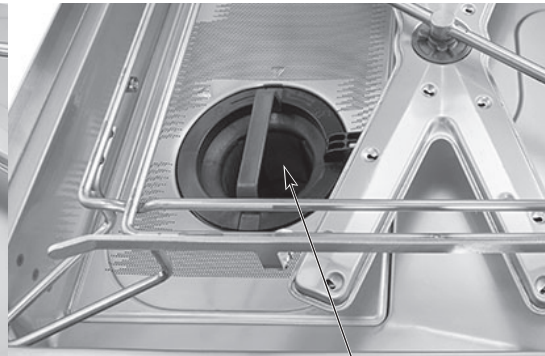

Fig. 18

NOTE: When installing the strainer basket, ensure the basket is in the 'locked' position (Fig. 19).



STRAINER BASKET IN UNLOCKED POSITION



STRAINER BASKET IN LOCKED POSITION

Fig. 19

If machine is equipped with ASR, ensure the external ASR scrap basket is properly installed in the ASR housing (Fig. 20).



Fig. 20

If machine is not equipped with Hobart built-in chemical pumps, an automatic detergent dispenser is required. Closely follow supplier's instructions.

Close the door. Press the POWER button to turn the power on (Fig. 21). If the machine's door is closed and no water is in the tank, the fill cycle will begin automatically. If water is detected in the tank, the machine will check the temperature of the water and if the water is cold, the machine will drain the water out prior to filling with fresh water. If the water is hot, the machine will proceed to heat the water to the wash tank temperature set point. During the fill cycle, the word FILLING is displayed along with an image of a bucket filling to show progress (Fig. 22).

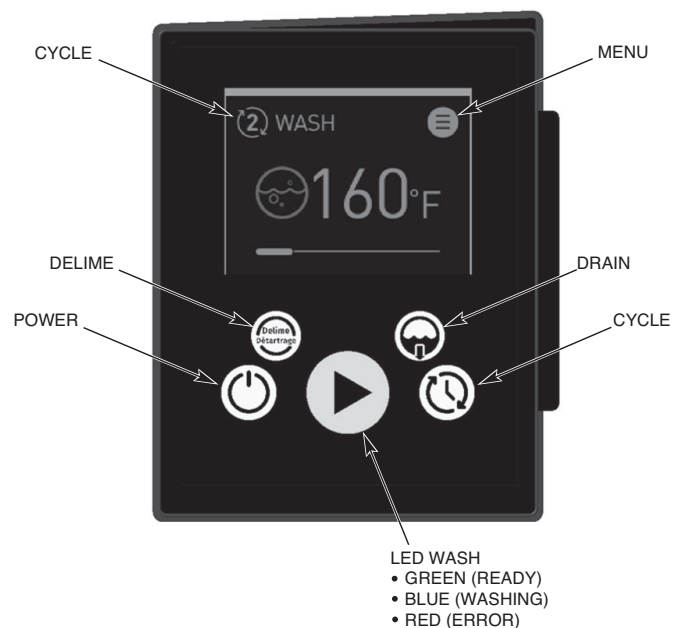

Fig. 21

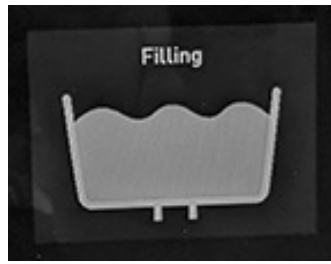

Fig. 22

NOTE: On machines equipped with the energy recovery feature, it may take up to 20 minutes to complete the fill process.

When washing or in idle mode, the readout displays the wash temperature. During the rinse cycle, the rinse icon and temperature are displayed. Select the wash cycle: 1 for normal serving ware, 2, 4 or 6 for pots and pans. Each wash cycle is followed by an automatic rinse. When the rinse cycle is complete and the rinse icon turns off, the door can be opened.

For ventless models, the door must remain closed until the condensing cycle is complete. All ventless models include a lock to prevent the door from opening until the cycle is complete. A condensing progress bar is displayed during the condensing cycle. Failure to follow these instructions will result in excess steam and water vapor in the dish room.

DISHWASHING

Scrape the dishes to remove large particles of food and debris. Never use steel wool on ware to be loaded into the dishwasher.

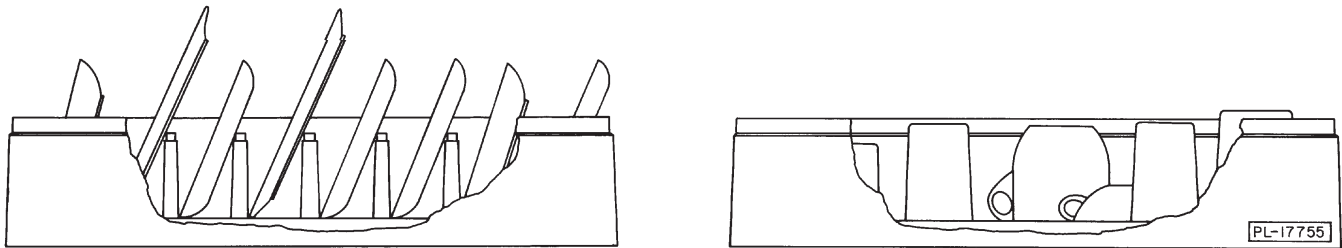

Fig. 23

Arrange the dishes in a rack. Do not stack dishes one on top of another, as water must have free access to all sides of every dish. Stand plates and dishes up edgewise in a peg-type rack (Fig. 23). Cups, glasses and bowls should be inverted in an open-type or compartment type rack (Fig. 23). Silverware and other small pieces may be scattered loosely over the bottom of a flat bottom rack.

Do not allow foreign objects to enter the unit, especially metallic contaminants.

After filling a rack, open the door, slide rack into the dishwasher and close the door.

Throughout the wash cycle, the tank water temperature is displayed on the front panel display, along with the word WASH and an icon. During the rinse cycle, the rinse water temperature is displayed, along with the word RINSE and an icon. When the rinse cycle is completed, the readout displays the tank water temperature.

On ventless models, a progress bar displays the remaining cycle time during the condense cycle.

When the display reads cycle complete, open the door, remove the clean dishes, slide in another rack and close the door.

This dish machine is not meant to be opened until a cycle has completed, but if a dish must be added after the wash cycle has started, open the door slowly, until the pump stops. Wait 10 seconds to allow the wash arm to coast down and to avoid water splashing before opening the door fully.

Operating temperatures for all models are as follows:

Sanitizing Mode	Wash Temperature Minimum Wash	Rinse Temperature Minimum Rinse
Hot Water	150°F (66°C)	180°F (82°C)
Chemical	120°F (49°C)	120°F (49°C)

For "VL" models only - If excessive amounts of steam or water vapor exit the machine after cycle is complete and door is opened, incoming cold water temperature may be too high. Contact Hobart Service to adjust the rinse and condense times according to the adjustment table shown below. Increasing cycle time will increase water consumption and decrease the racks per hour, but should reduce the steam and water vapor entering the dish room.

RECOMMENDED CONDENSE TIME (Based on Incoming Water Temp.)

AM16VL-BAS and AM16VL-ADV				
Incoming Water Temp. °F (°C)	Condense Time (Sec.)	Rinse Time (Sec.)	Racks per Hour Base Ventless (1 min cycle)	Racks per Hour ADV (1 min cycle)
60 (16)	20	10	45	40
65 (18)	24	10	42	39
70 (21)	27	10	41	37
75 (24)	30	10	40	36
80 (27)	33	11	38	35
85+ (29+)	36	12	36	33

AM16VLT-BAS, AM16VLT-ADV and AM16-SVLT				
Incoming Water Temp. °F (°C)	Condense Time (Sec.)	Rinse Time (Sec.)	Racks per Hour Base Ventless (1 min cycle)	Racks per Hour ADV (1 min cycle)
60 (16)	30	10	40	36
65 (18)	33	11	38	35
70 (21)	36	12	36	33
75 (24)	39	13	35	32
80 (27)	42	14	33	31
85+ (29+)	45	15	32	30

For AM16-SCB models only – Wash will not start if wash tank temperature is not up to 125°F (37°C) or if booster temperature is not up to 125°F (37°C). During this time, HEATING is shown on the display until wash and rinse temperatures reach 125°F (37°C).

If sanitizer supply is empty after 3 cycles, "Sanitizer is empty. Refill sanitizer. Machine is locked." will be displayed along with error code "Error 079" and the machine is inoperable. Replace sanitizer supply; sanitizer pump will prime automatically during the next cycle.

If detergent supply is empty, "Detergent is low. Refill detergent." will display along with error code "Error 074", but the machine will remain operable. Replace detergent supply; detergent pump will prime automatically during the next cycle.

For AM16SVLT models only – Wash will not start if the wash tank temperature is below 150°F (66°C). During this time, HEATING is shown on the display and the door will remain locked. If the machine fails to heat up, "Error 090" will be displayed and the machine will power down except for the display. After the wash cycle, if the booster temperature is below 181°F (83°C), the wash cycle will be extended up to 8 minutes before completing the rinse cycle. If the final rinse temperature does not reach 181°F (83°C), "Minimum final rinse temperature not reached. Machine locked" will be displayed along with "Error 084" and the machine will remain locked until it is drained and refilled.

If the detergent supply is empty after 3 consecutive cycles, "Detergent is empty. Refill detergent. Machine is locked." will be displayed along with error code "Error 077" and the machine is inoperable. Replenish the detergent supply, prime, then turn the machine off and back on again.

CLEANING

The machine must be thoroughly cleaned at the end of each working shift or at least daily. Never use steel wool to clean warewasher surfaces. Use only products formulated to be safe on stainless steel.

1. Press the Power button for 5 seconds (until progress bar is complete). The machine will automatically drain.
2. Once the display has powered off, open the machine door.
3. Thoroughly cleanse and flush the dishwasher interior. Remove remaining soil with a soft cloth or brush and mild cleanser. Rinse again.
4. Remove and empty the strainer basket, pan and standpipe. Wash and rinse thoroughly.
5. Clean tank bottom. Do not allow food soil to accumulate on the tank bottom or to enter the drain.
6. Remove standpipe. Wash and rinse standpipe inside and out.
7. Ensure upper and lower wash and rinse arms (Figs. 24, 25) rotate freely and are free of any obstructions. If not, remove arms and clear out any obstructions. Refer to Maintenance, page 33.

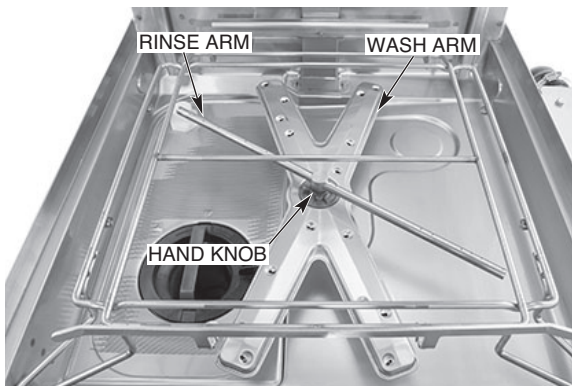

Fig. 24

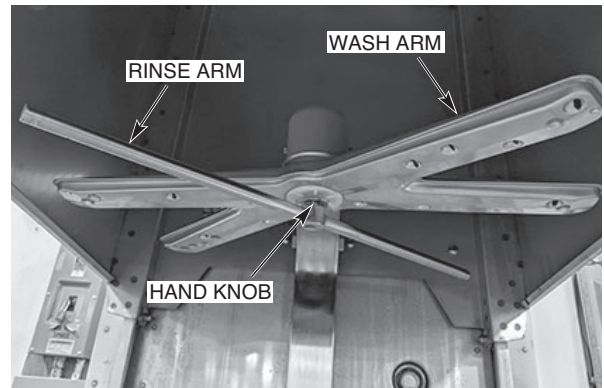

Fig. 25

NOTICE Do not bang wash arms or rinse arms to clean.

8. Press manual drain button (page 22, Fig. 21) until no water remains on tank bottom.
9. Replace all removed parts. Leave machine door open to allow interior to air out and dry.

DELIME INSTRUCTIONS

Manual Delime Process (Models AM16-BAS, AM16T-BAS, AM16VL-BAS, AM16VLT-BAS, AM16-SCB and AM16VL-SCB)

Machine will prompt operator when to delime based on a set number of cycles ran. When prompted, display will read 'Delime required. Start Delime Cycle?' If ready to delime, press either arrow button to highlight 'yes' and press the 'Enter' button. Press 'Enter' button on 'no' to delime machine later. If 'yes' is selected, proceed to Step 3 below. Start process at Step 1 if initiating manual delime process without the prompt.

1. Press the 'Delime' button.

2. Display will prompt 'Start Delime Cycle?'. Press either arrow button to highlight 'yes' and press the 'Enter' button.
3. Display will prompt 'Please Clean strainer'. Open machine door and remove strainer basket and strainer pan. Clean basket and pan in a sink with a mild detergent and rinse.
4. Replace strainer pan and strainer basket in machine and ensure basket is in the locked position (page 21, Fig. 19).
5. Close machine door and press the 'Enter' button. Machine will drain. Once machine has drained, the display will prompt 'Please insert delime'. Open machine door and pour required amount of delime chemical into wash tank according to chemical suppliers' recommendation for 10.5-gallon wash tank and close door.
6. Once door is closed, press the 'Enter' button. Tank will fill with fresh water. Once filled, the unit will begin a 10-minute wash cycle. Note: 'Enter' button will not appear on display until door is opened and closed.
7. After 10-minute wash cycle, machine will drain and re-fill with fresh water. Once filled, the unit will begin a 1-minute wash cycle to flush any remaining delime chemical residue.
8. After 1-minute wash cycle, the machine will drain and power down.

Auto Delime Process (Models AM16-ASR, AM16T-ASR, AM16VL-ADV, AM16VLT-ADV and AM16-SVLT)

Machine will prompt operator when to delime based on water hardness and machine usage. When prompted, display will read 'Delime required. Start Delime Cycle?' If ready to delime, press either arrow button to highlight 'yes' and press the 'Enter' button. Press 'Enter' button on 'no' to delime machine later. If 'yes' is selected, proceed to Step 3 below. Start process at Step 1 if initiating auto delime process without the prompt.

NOTE: Machine will automatically pump delime solution into dish machine during auto delime cycle. Ensure sufficient chemical is present in bottle and standpipe is fully inserted into bottle.

1. Press the 'Delime' button.
2. Display will prompt 'Start Delime Cycle?'. Press either arrow button to highlight 'yes' and press the 'Enter' button.
3. Display will prompt 'Please Clean strainer'. Open machine door and remove strainer basket and strainer pan. Clean basket and pan in a sink with a mild detergent and rinse.
4. Replace strainer pan and strainer basket in machine and ensure basket is in the locked position (page 21, Fig. 19).
5. Close machine door and press the 'Enter' button. Machine will drain. Once machine has drained, machine will begin to re-fill with fresh water and automatically add delime solution as the unit fills.
6. Once unit has filled and delime solution has been added, the unit will begin a 10-minute wash cycle.
7. After 10-minute wash cycle, machine will drain and re-fill with fresh water. Once filled, the unit will begin a 1-minute wash cycle to flush any remaining delime chemical residue.
8. After 1-minute wash cycle, the machine will drain and power down.

DOS AND DON'TS FOR YOUR NEW HOBART WAREWASHER

DO assure proper water hardness (3 grains or less per gallon is recommended).

DO pre-scrap dishes thoroughly.

DO use only detergents recommended by your chemical professional.

DO at the end of the day, thoroughly cleanse the machine, rinse and dry (leave door open).

DO closely follow your chemical professional's prescribed delimiting schedule.

DO use only products formulated to be safe on stainless steel.

DO NOT use detergents formulated for residential dishwashers.

DO NOT allow food soil to accumulate on the tank bottom.

DO NOT exceed chemical manufacturer's recommended concentrations for detergent, sanitizer, rinse aid or lime scale remover.

DO NOT use steel wool to clean ware or warewasher surfaces.

DO NOT allow foreign objects to enter the unit, especially metallic contaminants such as paper clips, retainers, etc.

NOTE: Failure to follow use, care and maintenance instructions may void your Hobart warewasher warranty.

MANAGER MENU

The AM16 dish machines allow customization options for machine operation. To activate or change these features, enter the Manager Menu using the following procedure.

1. Power on dishwasher. Display shows ready screen when fill cycle has completed.
2. Press 'Menu' button.
3. With 'Manager Menu' highlighted, press the 'Enter' button. The 'Enter PIN' screen will be displayed.
4. The default manager code is 1001. Use the arrow buttons to change the value and then press the 'Enter' button to select the value and toggle to the next digit until the code is entered.
5. Use the Up and Down Arrows to toggle thru the Manager Menu.
 - a. Once the desired selection is outlined, press the Enter button.
 - b. For selections that are editable, use the Up and Down arrows to change the value.
 - c. Once the required value is displayed, press the 'Enter' button to save the selection.
6. To exit the programming, use the Up and Down arrows to scroll thru the parameters until 'back' is outlined and press the 'Enter' button. Repeat this procedure until the Ready screen is displayed.

MANAGER MENU PARAMETERS

Parameter Name	Description	Possible Values	Default Value
MACHINE SETTINGS			
Language	Sets the language for machine display.	English, French, Spanish, etc.	English
Date	Sets the current day, month, year.		
Time	Selects the current time (hours & minutes). Time can also be updated to 24h format.		
Temperature Units	Sets the temperature displays to Fahrenheit or Celsius.	Fahrenheit or Celsius	Fahrenheit
DISPLAY SETTINGS			
Brightness	Increases or decreases the brightness of the machine display screen.		
MACHINE ALARM			
Machine Alarm	Enables or disables an end of cycle audible alarm.	Enable or Disable	Enable
CHEMICAL MENU			
Rinse Aid Concentration	Sets the rinse aid chemical concentration level.	0.0 ml/L - 2.0 ml/L	0.3 ml/L
Detergent Concentration	Sets the detergent chemical concentration level.	0.0 ml/L - 9.5 ml/L	0.8 ml/L
Prime Chemical Pumps	Refer to Chemical Pump Priming, page 16.		
Sanitizer Dosing	Sets the sanitizer chemical concentration level.	0% - 100%	11%
Delime Concentration	Sets the delime chemical concentration level based on % delimer in solution with sump & booster tank water.	Low (1.25%) Medium (1.89%) High (3.77%)	Low (1.25%)
WATER HARDNESS			
Water Hardness	Sets the water supply water hardness.	0 gr/gal - 250 gr/gal	7 gr/gal
MACHINE CYCLE LOG			
Show Cycle Information	Displays date and time of previous cycles.		
AUTOMATIC START *			
Enable/Disable	Allows the automatic start feature to be disabled or enabled.	Enable or Disable	Disable
Settings	Sets the automatic start day of week and time. If feature is enabled, machine will automatically power on and fill at day and time set.		

Parameter Name	Description	Possible Values	Default Value
WiFi			
Enable/Disable	Enables or disables WiFi connectivity.	Enable or Disable	Disable
Status	Displays the current WiFi connection status of the machine.		
Connection Assistant	Guided connection to WiFi network.	<ul style="list-style-type: none"> • Search Network • WPS • Add Network 	
Access Code	Generates an access code that can be used to pair the machine to the SmartConnect App.		
Connection Test	Tests the WiFi connection with the machine to confirm WiFi connectivity.		
Manual Installation	Allows connectivity to a hidden network.	<ul style="list-style-type: none"> • Search Network • WPS • Add Network 	
CYCLES UNTIL DELIME NOTIFICATION (ONLY APPLIES TO AM16(T)-BAS, AM16VL(T)-BAS, AM16-SCB & AM16VL-SCB MODELS)			
Cycles Until Delime Notification	Displays remaining cycles until delime reminder notification is displayed.		
Set Counter	Sets the number of cycles until the delime reminder notification is displayed.	0-999999	2000
DELAY WASH PROGRAM			
Enable/Disable	Enables or disables wash tank temperature delay. If enabled, wash cycle will be delayed until minimum wash temperature is reached. Display will show 'Heating' until temperature is reached.	Enable or Disable	Disable
RINSE TEMPERATURE ALERT			
Disabled	Disables low rinse temperature alert.		
Notification	Enables low rinse temperature alert. After set number of cycles (default 3) below minimum rinse temperature requirement, display will show rinse temperature alert warning. Machine will continue to function as normal.		

Parameter Name	Description	Possible Values	Default Value
Lockout Machine	Enables low rinse temperature lockout. After set number of cycles (default 3) below minimum rinse temperature requirement, display will show rinse temperature alert warning. Machine will lockout and unit will be inoperable.		
Repeat Cycle	After set number of cycles (default 3) below minimum rinse temperature requirement, machine will automatically repeat wash and rinse cycles.		

* **NOTE:** When enabling Automatic Start feature, machine will power on and fill while unattended. Prior to using this feature, ensure all machine panels and components are in place and that all facility connections to the machine (i.e.: water, drain, electric) are in working order.

HOBART SMARTCONNECT APP

Thanks to built-in WiFi, you can connect your AM16 commercial dishwasher to our easy-to-use smart phone app. With the free Hobart SmartConnect app, you can create better procedures and enhance performance in the dishroom by monitoring sanitization and analyzing usage, consumption and costs.

NOTE: For 240-volt, 380-volt and 440-volt supplies, contact Hobart Service to adjust the power value in the service settings for accurate energy consumption values.

Getting Connected

Registering an Account

1. Open the app and tap on **Register**.
2. Enter your email and tap **Send Verification Code**. Then enter the code you receive to your email.
3. Provide the remaining information, including a password.
4. Tap **Create**.
5. Read and agree to the End User License Agreement and Privacy Policy. Tap **Confirm** when you are done.

You can now use the app to connect to WiFi and pair your machine.

Connecting the AM16 to WiFi from the SmartConnect App

1. Tap on the hamburger menu icon, then tap on the “**WiFi**” button.
2. Tap on “**Connect**” for Hobart.
3. Follow the guide in the app to prepare the machine for connection.
4. Tap on “**Confirm Instructions**” and tap “**Yes**” if the machine is ready for connection.
5. The machine will generate a code; enter this into the app and it will connect with the machine.

6. A list of available networks will be displayed. Select the network you want to connect with and enter the network password if necessary.
7. When the WiFi connection is successful, the machine will indicate success and display an access code to pair with the app.
8. From the main screen of the app, tap on the hamburger menu icon, then tap on the "+" button and enter the access code to pair.

Connecting the AM16 to WiFi from the Machine

1. Tap on the "Hamburger Menu Icon", select "**Manager Menu**" and enter your pin.
2. Scroll and tap the "**Enter**" button to select "**WiFi**".
3. Scroll and select "**Connection Assistant**".
4. Scroll and select "**Search Network**".
5. Scroll and select the available network you wish to connect to.
6. Enter the password for your network, then tap "**OK**".
7. The machine will connect to your network, transfer data to the SmartConnect Cloud and display a connection code for the app.

If your machine won't connect to the WiFi, go to our FAQs at www.itwfoodequipment.com/smartconnect365/help to troubleshoot your connection.

To Pair and Add your AM16 to the App

Before pairing, make sure your machine is connected to WiFi using the previous steps. To pair your Hobart AM16 to the SmartConnect App:

From the Dishmachine

1. Tap the menu icon to enter the manager menu on your dishmachine.
2. Select "**Manager Menu**" and enter your pin.
3. Scroll and select "**WiFi**".
4. Scroll and select "**Access Code**".
5. An activation code will be generated and displayed. This code is valid for 48 hours.

From the App

1. Tap on the "+" button at the bottom of the machine list.
2. Enter the activation code found in the manager menu of the machine's touchscreen, then tap **Submit**.
3. Select your service provider from the drop-down menu.
4. Tap **Finish**.

Your machine will now appear in the machine list on the home screen of the app.

For more information about SmartConnect, including usage instructions, troubleshooting for your WiFi connection and other general questions, visit the SmartConnect Help and FAQ guide at www.itwfoodequipment.com/smartconnect365/help.

MAINTENANCE

⚠ WARNING Disconnect the electrical power to the machine (both dishwasher and booster if applicable) and follow lockout / tagout procedures. Be sure all circuits are disconnected.

WASH ARMS

Upper and lower wash and rinse arms (page 26, Figs. 24, 25) should turn freely and continue turning for a few seconds after being rotated by hand. Remove any obstructions causing improper operation.

If either the strainer pan or the strainer basket is not properly in place, obstructions (such as food particles or bones) may clog the wash arm nozzles. The wash arms are easily removed for cleaning.

To remove the lower wash arm, unscrew the hand knob and lift the rinse arm off (Fig. 24). The wash arm can be lifted off once the rinse arm is removed.

The upper wash and rinse arms are removed by unscrewing the hand knob (Fig. 25) and lowering both arms together. Be careful not to drop the arms.

MOTOR(S)

The wash pump motor, rinse pump motor, drain pump motor and fan motor ("VL" models only) are equipped with permanently lubricated bearings and require no lubrication maintenance.

CHEMICAL PUMPS

If unit has built-in Hobart chemical pumps, inspect chemical tubes every 6 months and replace as required.

CLEANING BAFFLES ON AM16VLT-BAS, AM16VLT-ADV AND AM16-SVLT MODELS

The baffles (upper and lower), located on the back wall of the inside of the machine (Fig. 26), should be cleaned every 6 months or sooner if required.

⚠ WARNING Disconnect the electrical power to the machine (both dishwasher and booster if applicable) and follow lockout/tagout procedures. Be sure all circuits are disconnected.

1. Loosen and remove the nuts from each baffle and remove the baffles.
2. Debris may collect on surfaces of baffles and should be washed in a sink with a mild detergent and rinsed.
3. Replace baffles using nuts removed in Step 1.
4. Leave machine door open to allow interior to air out and dry.

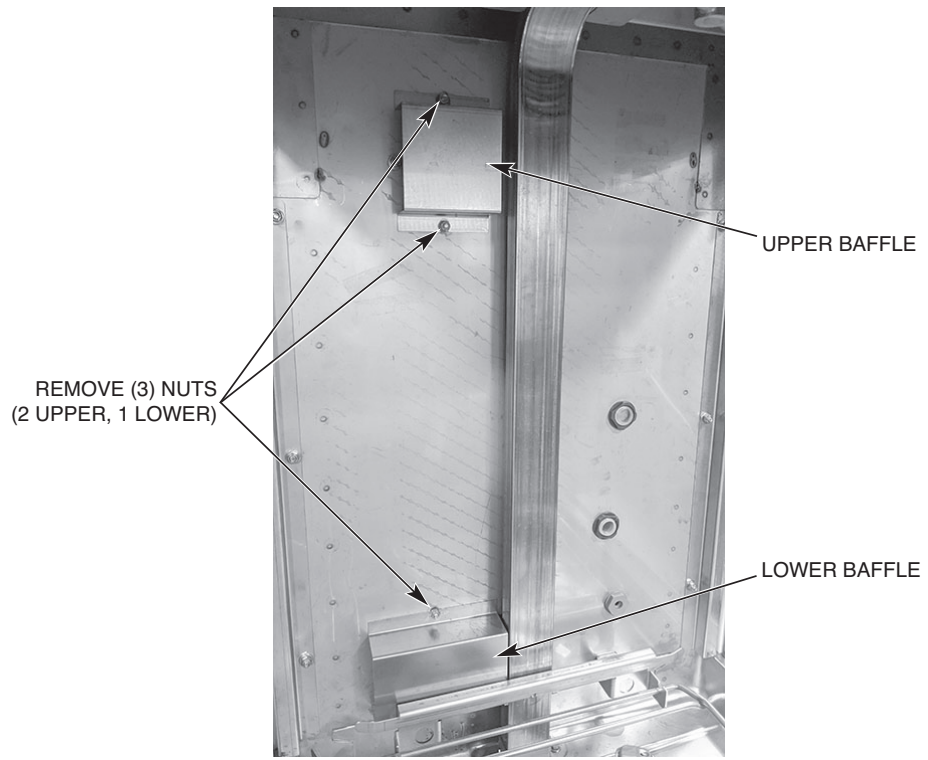

Fig. 26

TROUBLESHOOTING

ERROR CODE CHART WITH POSSIBLE SOLUTIONS

Error No.	Text On Screen	Error Description	Troubleshooting
001	Booster temperature error.	The booster temperature is 239°F/115°C or greater.	Press and hold the power button for 5 seconds to clear the error. The machine will drain and power off. If the error persists, contact Hobart Service.
002	Booster temperature error.	The booster temperature is 32°F/0°C or lower.	Press and hold the power button for 5 seconds to clear the error. The machine will drain and power off. If the error persists, contact Hobart Service.
003	Booster temperature not reached during fill cycle.	During the fill cycle, the booster temperature did not meet the setpoint within the predetermined time.	Press the ENTER button to clear the error. If the error persists, contact Hobart Service.
004	Booster temperature not reached during wash cycle.	During the wash cycle, the booster temperature did not meet the setpoint within the predetermined time.	Press the ENTER button to clear the error. If the error persists, contact Hobart Service.
006	Wash temperature error.	The wash tank temperature is 239°F/115°C or greater.	Press and hold the power button for 5 seconds to clear the error. The machine will drain and power off. If the error persists, contact Hobart Service.
007	Wash temperature error.	The wash tank temperature is 32°F/0°C or lower.	Press and hold the power button for 5 seconds to clear the error. The machine will drain and power off. If the error persists, contact Hobart Service.
008	Wash tank temperature not reached during fill cycle.	During the fill cycle, the wash tank temperature did not meet the setpoint within the predetermined time.	Press the ENTER button to clear the error. If the error persists, contact Hobart Service.
009	Wash tank temperature not reached during wash cycle.	During the wash cycle, the wash tank temperature did not meet the setpoint within the predetermined time.	Press the ENTER button to clear the error. If the error persists, contact Hobart Service.
014	Booster pressure sensor failure.	The maximum booster water level has been exceeded. The machine will not run.	Press and hold the power button for 5 seconds to clear the error. The machine will drain and power off. If the error persists, contact Hobart Service.
015	Booster pressure sensor failure.	The minimum booster water level has not been reached. The machine will not run.	Press and hold the power button for 5 seconds to clear the error. The machine will drain and power off. If the error persists, contact Hobart Service.
016	Wash tank pressure sensor failure.	The maximum wash tank water level has been exceeded. The machine will not run.	Press and hold the power button for 5 seconds to clear the error. The machine will drain and power off. If the error persists, contact Hobart Service.
017	Wash tank pressure sensor failure.	The minimum wash tank water level has not been reached. The machine will not run.	Press and hold the power button for 5 seconds to clear the error. The machine will drain and power off. If the error persists, contact Hobart Service.

Error No.	Text On Screen	Error Description	Troubleshooting
018	Wash tank water level is too high.	Wash tank water level is above the upper limit.	Press and hold the manual drain button for 5 seconds to drain the unit back to normal level. Press the ENTER button if displayed to clear the error. If the ENTER button does not display, press and hold the power button for 5 seconds. Machine will drain and power off. If the error persists, contact Hobart Service.
019	Tank strainer blocked. Remove strainer, clean and put back in place.	Tank strainer pan is blocked.	Remove, clean and replace strainer pan. Press the ENTER button to clear the error. The machine will drain and power down if the water level is low. If the water level has returned to normal, the machine will power off, but not drain. Power machine on to continue operation.
020	Wash tank pressure sensor error. Drain and restart machine.	The wash tank water level did not increase by the anticipated amount after being filled by the rinse cycle.	Press the ENTER button to clear the error. The machine will drain and clear the error. Ensure tank is clean. If the error persists, contact Hobart Service.
021	Drain hose is clogged. Clean drain hose and drain machine again.	Significant water remains in wash tank after drain cycle.	Ensure power to machine is off and wash water has cooled. Verify standpipe and bottom of wash tank are free of debris. Clean the drain hose and drain the machine. Ensure drain hose is not kinked and installed properly. If error remains on screen, press and hold the power button for 5 seconds to clear the error. Machine will drain and power down.
022	Drain hose is clogged. Clean drain hose.	During wash cycle, water level not maintained at normal level.	Ensure power to machine is off and wash water has cooled. Verify standpipe and bottom of wash tank are free of debris. Clean the drain hose and drain the machine. Ensure drain hose is not kinked and installed properly. If error remains on screen, press the ENTER button to clear the error.
023	Fill system timeout, inspect incoming water line.	The fill valve has been active for more than the maximum allowed fill time, and the wash tank water level has not been reached. This error will only occur if unit is equipped with rapid fill.	Ensure incoming water supply is turned on and that fill hose is not kinked. Verify water pressure is 15-65 psi. Press the ENTER button to clear the error. If the error persists, contact Hobart Service.
029	Program interrupted. Close door.	Door is opened during machine operation.	Close the door and ensure door is fully seated. The current operation resumes. If the error persists, contact Hobart Service.
032	Fill error, inspect incoming water line.	The booster water level did not reach the proper level within the set amount of time.	Ensure incoming water supply is turned on and that fill hose is not kinked. Verify water pressure is 15-65 psi. Press the ENTER button to clear the error. If the error persists, contact Hobart Service.

Error No.	Text On Screen	Error Description	Troubleshooting
033	Fill valve error.	The fill valve has been active for more than the maximum allowed fill time.	Ensure incoming water supply is turned on and that fill hose is not kinked. Verify water pressure is 15-65 psi. Press the ENTER button to clear the error. If the error persists, turn water supply off and contact Hobart Service.
035	Ensure tank strainer is locked in place.	The internal scrap basket is not inserted, or it is not in the locked position.	Ensure scrap basket is properly installed and in the locked position. The arrow on the scrap basket should line up with the arrow on the strainer pan. If installed properly, the error will clear automatically. (Refer to page 21, Fig. 19)
038	Incoming power to machine is too high. Machine has powered down.	The incoming voltage is higher than the maximum required machine voltage.	The incoming voltage must be at or below the required machine voltage (see machine data plate). Turn circuit breaker supply off and ensure unit is connected with proper voltage supply.
039	Fill cycle interrupted. Close door.	Door is opened during the fill cycle.	Close the door and ensure door is fully seated. The fill cycle resumes. If the error persists, contact Hobart Service.
049	Communication between the controls has been interrupted.	Interruption of communication between control board and touchscreen display.	Communication between the controls should be automatically restored. If the problem persists, contact Hobart Service.
052	Drain hose is clogged.	Wash tank water level is above the upper limit.	Ensure power to machine is off and wash water has cooled. Verify standpipe and bottom of wash tank are free of debris. Clean the drain hose and drain the machine. Ensure drain hose is not kinked and installed properly. If error remains on screen, press and hold the power button for 5 seconds to clear the error. Machine will drain and power down.
054	ASR strainer basket not detected. Place ASR strainer basket in ASR box.	The ASR basket is not detected.	Ensure the ASR strainer basket is properly installed. If installed properly, the error will clear automatically. To run machine without ASR, press the ENTER button to acknowledge the error for one cycle. If the error persists, contact Hobart Service.
057	Wash tank is filling. Cycle will begin when water is replenished.	Wash tank water level is low at start of wash cycle.	Machine automatically fills while error is displayed. Once proper water level is reached, wash cycle will begin.
059	Cloud connection not available.	WiFi is connected, data cannot be sent to the cloud.	Tap on HELP in Smart Connect app and refer to the troubleshooting in the FAQ's for guidance.
070	Minimum wash temperature not reached.	The wash temperature did not reach the minimum set point requirement.	Press the ENTER button to clear the error. If the error persists, contact Hobart Service.
071	Minimum rinse temperature not reached.	The rinse temperature did not reach the minimum set point requirement.	Press the ENTER button to clear the error. If the error persists, contact Hobart Service.

Error No.	Text On Screen	Error Description	Troubleshooting
074	Detergent empty. Refill detergent.	The detergent has not been sensed for the set number of consecutive cycles.	Ensure detergent is present in bottle and that cap & tube are properly secured to bottle. Replace detergent bottle if empty. Press the ENTER button to prime the detergent pump. Repeat as required.
075	Rinse aid empty. Refill rinse aid.	The rinse aid has not been sensed for the set number of consecutive cycles.	Ensure rinse aid is present in bottle and that cap & tube are properly secured to bottle. Replace rinse aid bottle if empty. Press the ENTER button to prime the rinse aid pump. Repeat as required.
076	Sanitizer empty. Refill sanitizer.	The sanitizer has not been sensed for the set number of consecutive cycles.	Ensure sanitizer is present in bottle and that cap & tube are properly secured to bottle. Replace sanitizer bottle if empty. Press the ENTER button to prime the sanitizer pump. Repeat as required.
077	Detergent empty. Machine locked.	Detergent has not been sensed for three consecutive cycles.. The machine will be locked out until detergent is replaced.	Ensure detergent is present in bottle and that cap & tube are properly secured to bottle. Replace detergent bottle if empty. Press the ENTER button to prime the detergent pump. Repeat as required.
079	Sanitizer empty. Machine locked.	Sanitizer has not been sensed for three consecutive cycles. The machine will be locked out until detergent is replaced.	Ensure sanitizer is present in bottle and that cap & tube are properly secured to bottle. Replace sanitizer bottle if empty. Press the ENTER button to prime the sanitizer pump. Repeat as required.
080	Delime required. Run delime cycle.	If delime lockout is enabled, machine will lock out due to delime reminder being ignored 10 times.	Press the DELIME button and run a delime cycle to reset the delime reminder.
081	Final rinse temperature too high.	Final rinse temperature is 239°F/115°C or greater.	Press and hold the power button for 5 seconds to clear the error. The machine will drain and power off. If the error persists, contact Hobart Service.
082	Final rinse temperature too low.	Final rinse temperature is 32°F/0°C or lower.	Press and hold the power button for 5 seconds to clear the error. The machine will drain and power off. If the error persists, contact Hobart Service.
083	Minimum final rinse temperature not reached.	The final rinse temperature did not reach minimum final rinse temperature after three consecutive cycles.	Press the ENTER button to clear the error. If the error persists, contact Hobart Service.
084	Minimum final rinse temperature not reached. Machine locked.	If final rinse lockout is enabled and the final rinse temperature did not reach minimum final rinse temperature after three consecutive cycles, the machine will lock out.	Press and hold the power button for 5 seconds to clear the error. The machine will drain and power off. If the error persists, contact Hobart Service.

Error No.	Text On Screen	Error Description	Troubleshooting
085	Wash tank overtemp tripped.	Wash tank overtemp has been tripped.	Error cannot be cleared until overtemp has been reset. Contact Hobart Service.
086	Booster overtemp tripped.	Booster overtemp has been tripped.	Error cannot be cleared until overtemp has been reset. Contact Hobart Service.
087	Minimum final rinse temperature not reached after repeating cycle.	The final rinse temperature is less than the set point.	Press and hold the power button for 5 seconds to clear the error. The machine will drain and power off. If the error persists, contact Hobart Service.
088	Wash tank heater contactor error. Contact service.	Wash tank heater remains on while ignoring software command to turn off.	Machine is running a fill and drain cycle to protect the heater. This error is not user serviceable. Turn circuit breaker supply off and contact Hobart Service.
089	Booster heater contactor error. Contact service.	Booster heater remains on while ignoring software command to turn off.	Machine is running a fill and drain cycle to protect the heater. This error is not user serviceable. Turn circuit breaker supply off and contact Hobart Service.
090	Temperature not reached. Drain and restart machine. If necessary contact service technician.	The wash temperature did not reach the minimum set point requirement within time out period (SCB and SVLT models only).	Press and hold the power button for 5 seconds to clear the error. The machine will drain and power off. If the error persists, contact Hobart Service.

COMMUNICATION MODULE

For AM16-SCB models equipped with the sPod® embedded communication module, the unit will automatically connect to a SiteSage® gateway and begin transmitting relevant data for remote monitoring at start-up. If problems arise, contact the support group for your communication system supplier.

SYMPTOM	POSSIBLE CAUSE
No machine operation.	<ol style="list-style-type: none"> 1. Machine off, turn machine on. 2. Blown fuse or tripped circuit breaker at power supply.
Dishes not clean.	<ol style="list-style-type: none"> 1. Loss of water pressure due to pump obstruction. ⚠ WARNING Disconnect electrical power supply (both dishwasher and booster if applicable) and drain tank. Remove strainer and standpipe and check pump & drain intake for obstruction. 2. Incorrect water temperature. Contact Service for adjustment or repair. 3. Excessive mineral deposits throughout wash and rinse system. Deliming may be necessary, refer to page 26. 4. Check wash and rinse arms to ensure there are no obstructions and ensure they rotate properly. 5. Strainers clogged causing inadequate water supply to pump; clean machine according to Cleaning, page 26. 6. Ensure chemical dispenser is operating properly. 7. Excessive soil; scrap dishes before cycle 8. Improper rack loading; refer to Preparation and Dishwashing, Pages 21, 23.

SYMPTOM	POSSIBLE CAUSE
Spotting silverware, glasses and dishes.	<ol style="list-style-type: none"> 1. Improperly loaded racks. 2. Incorrect rinse water temperature. 3. Loss of water pressure due to pump obstruction. <p>⚠ WARNING Disconnect electrical power supply (both dishwasher and booster if applicable) and drain tank. Check for any obstruction at the pump intake.</p> <ol style="list-style-type: none"> 4. Excessively hard water. 5. Incorrect detergent for water type. 6. Incorrect rinse additive for water type. 7. Incorrect concentration of detergent, rinse additive and/or sanitizer. 8. Excessive soil; scrap dishes before cycle. Ensure wash tank is drained and cleaned as required.
Excessive steam or water vapor after cycle is complete – AM16VL-BAS, AM16VLT-BAS, AM16VL-ADV, AM16VLT-ADV and AM16SVLT models only.	<ol style="list-style-type: none"> 1. Incoming cold water too warm. Contact Hobart Service for adjustment of condensing cycle time.
Inadequate rinse or rinse water temperature too low.	<ol style="list-style-type: none"> 1. Excessive mineral deposits throughout wash and rinse system. Deliming may be necessary, refer to page 26. 2. For non-ventless hot machines, incoming water temperature to booster below 110°F. For ventless machines, incoming water temperature to machine below 55°F. Machine will automatically extend wash time until booster heats up. 3. Ensure rinse arms rotate freely.
Leaking valve.	<ol style="list-style-type: none"> 1. If hose connection at valve is leaking, check hose gasket to ensure it is seated properly and not worn or cut. 2. If solenoid valve is malfunctioning (leaking, not opening or not closing), contact Hobart Service.
Low/no wash tank heat.	<ol style="list-style-type: none"> 1. Ensure sufficient water level in tank. 2. Ensure heating element is clean and free of excessive lime scale.
No or slow fill.	<p>Note: Fill time could be as high as 25 minutes.</p> <ol style="list-style-type: none"> 1. Water supply may be off; make sure hot water supply valve is open. 2. Dirty strainer at fill hose connection causing reduced water flow. Turn off hot water supply, remove fill hose and clean screen. Reassemble.
ASR overflowing (if machine is equipped with ASR)	<ol style="list-style-type: none"> 1. Ensure drain line is not clogged. 2. Ensure ASR basket is clean and properly installed.
Not dispensing chemicals (on machines equipped with Hobart chemical pumps).	<ol style="list-style-type: none"> 1. Ensure chemical bottles are full. 2. Ensure chemical bottle caps are properly secured. 3. Inspect tubing and ensure it is tight to bottle caps. 4. Manually prime chemicals. If unsuccessful, contact Hobart Service.

SERVICE

AM16 EXPENDABLE PARTS

The below AM16 dish machine parts are expendable by nature and may not be covered by Hobart Product Warranty. To view the Hobart Product Warranty, refer to <https://www.hobartservice.com/service-plans/hobart-product-warranty>.

AM16 EXPENDABLE PARTS LIST

Part Number	Description	Qty.	Machine Type
00-443581	USB plug	1	All
00-918049	Lift arm plug	2	All
00-893834	Seal, top cover, tall AM	3	Tall
00-975055	Hub, wash arm	2	All
00-886610	Kit, wash arm plug	1	All
00-562078	Retaining ring	2	All
00-185112	Standpipe (delime)	1	Advansys / ASR
00-185105-00029	Tubing, black, 144"	1	Advansys / ASR
00-13156-00001	Clamp (spring action hose)	AR	Advansys / ASR
00-949651-00001	Squeeze tube kit, chemical pump (sanitizer, rinse aid, detergent) (Includes hose clamps)	3	SCB / SVLT
00-185105-00002	Tubing, red, 144", 1/4"	1	SCB
00-185105-00006	Tubing, blue, 144", 1/4"	1	SCB
00-185105-00004	Tubing, clear, 144", 1/4"	1	SCB
00-185105-00013	Tubing, clear, 6"	2	SCB
00-185105-00024	Tubing, clear, 66"	1	SCB
00-562915	Kit, replacement chemical cap	1	SCB
00-975024	Assembly, suction strainer	AR	SCB
00-185111-00001	Clamp #2	AR	SCB
00-463293	Tube, sight	1	SVLT
00-185111-00002	Clamp, hose 7/16	AR	SVLT
00-474800	Rack, 6-pan	AR	Tall
00-315191	Peg rack	AR	All
00-315193	Combination rack	AR	All

Contact your local Hobart-authorized service office for any repairs or adjustments needed on this equipment. Long-term service contracts are available on this and other Hobart products. Call 1-888-4HOBART for Hobart Service 24 hours a day.

