

# RackStar® 66

Project \_\_\_\_\_  
 Item \_\_\_\_\_  
 Quantity \_\_\_\_\_  
 CSI Section 11400  
 Approval \_\_\_\_\_  
 Date \_\_\_\_\_

## Models

RackStar 66



### Standard Features

- Adjustable Rinse System
- Rainbow Rinse™ with arched rinse arm design
- 19-3/4" (502 mm) clearance
- WISR® Cleaning System
- Double-wall insulated doors retain heat, keeping wash water hot & generating less heat in the dish room
- Self-cleaning wash arms
- 22" pre-wash
- Fully automatic, including auto-fill
- Adjustable vent cowl collars
- Exclusive EnergyGuard™ controls
- Self-draining stainless steel wash pump
- Digital LED control panel
- Strike plate table limit switch
- Large front access for ease of maintenance
- Stainless steel strainer pans
- Splash shields
- Stainless steel frame and legs
- Exhaust vent fan control
- 15kW wash tank heater
- Front dress panel
- Adjustable bullet feet

### Mandatory Specs

Specify:

- Electric  
 Steam

Specify Voltage \_\_\_\_\_

Specify Sanitizing Method:

- High Temperature  
 Chemical Sanitizing

Specify Direction of Operation:

- Left to Right  
 Right to Left

### Options

- Higher than Standard Chamber Height  
 Onboard Booster  
 40° F (22.2° C) Rise  
 70° F (38.9° C) Rise  
 Single Point Connection with Onboard Booster (3 phase only)  
 Steam Booster Heater  
 23" (584 mm) Unhooded Side Loader  
 30" (762 mm) Unhooded Side Loader  
 1/2" Pressure Regulator  
 Flanged Feet  
 Prison Package

### Accessories

- 36-Compartment Rack  
 4-1/8" tall (104 mm)  
 5 - 5/8" tall (143 mm)  
 7" tall (178 mm)  
 Combination Rack  
 Peg Rack  
 Sheet Pan Rack  
 Drain Quench System  
 Scaltrol  
 Water Hammer Arrestor

### Specifications

Uses 0.35 gallons of water (1.32 liters) per rack in Econo Rinse mode

Uses 0.52 gallons of water (1.97 liters) per rack in Turbo Rinse mode

Cleans 223 racks per hour

22" (559 mm) pre-wash section has 3 upper and 1 lower pre-wash arms

Durable stainless steel construction



Intertek



# RackStar® 66

Left to Right

## LEGEND

- A - Electrical Connection
- B - Main Water Inlet  
(1/2" NPT, 110 °F MIN (18 kW Booster),  
140 °F MIN (12 kW Booster), or 180 °F MIN  
(No Booster or Supplied from Steam Booster))
- C - Drain Connection  
(1 1/2" NPT)
- D - Vent Connections  
(Including Dampers)
- E - Steam Connection  
(3/4" NPT)

- — — — — - Open Door
- - - - - - - - - - - High Hood Option

All dimensions from the floor can be increased 1 3/4" using the machine's adjustable feet.

Items in red are not supplied with the machine.

Items in blue are for the Steam option.

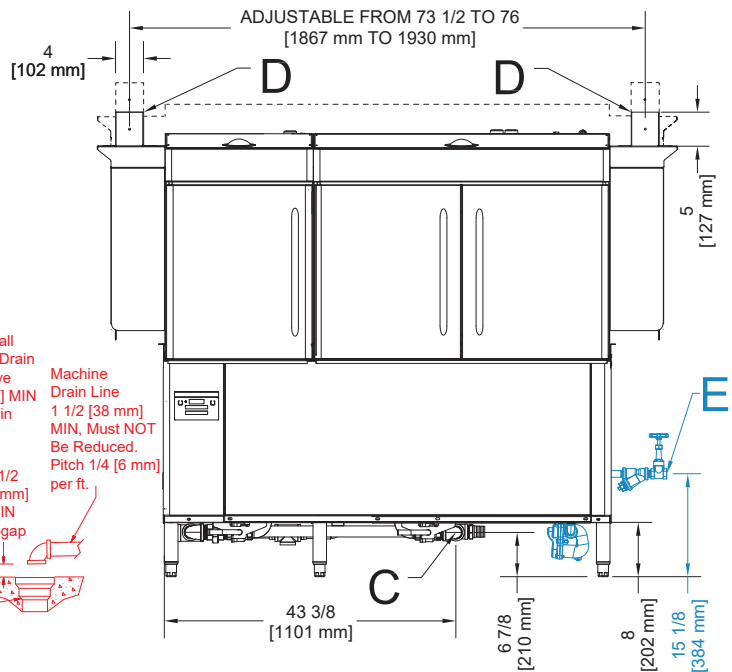
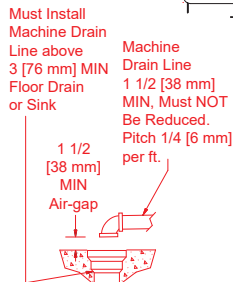
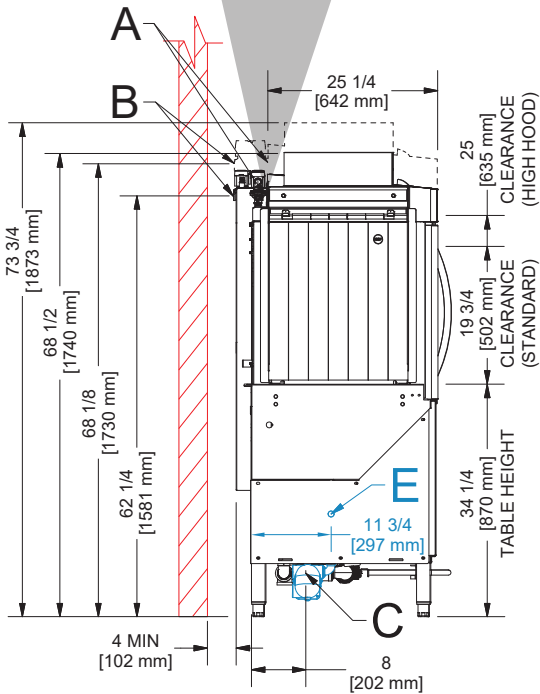
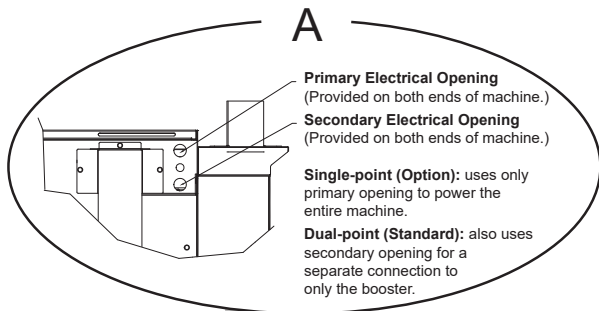
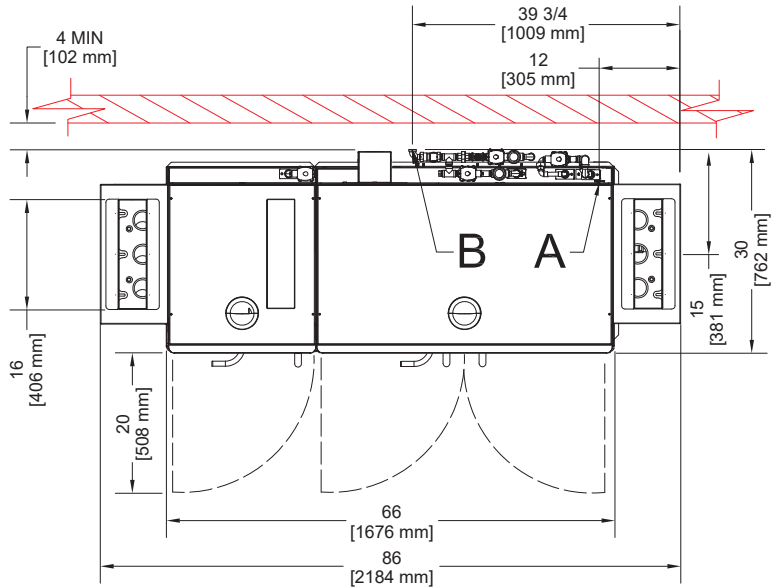

## LEGEND

- A - Electrical Connection
- B - Main Water Inlet  
(1/2" NPT, 110 °F MIN (18 kW Booster),  
140 °F MIN (12 kW Booster), or 180 °F MIN  
(No Booster or Supplied from Steam Booster))
- C - Drain Connection  
(1 1/2" NPT)
- D - Vent Connections  
(Including Dampers)
- E - Steam Connection  
(3/4" NPT)
- - Open Door
- - High Hood Option

All dimensions from the floor can be increased 1 3/4" using the machine's adjustable feet.

Items in red are not supplied with the machine.

Items in blue are for the Steam option.

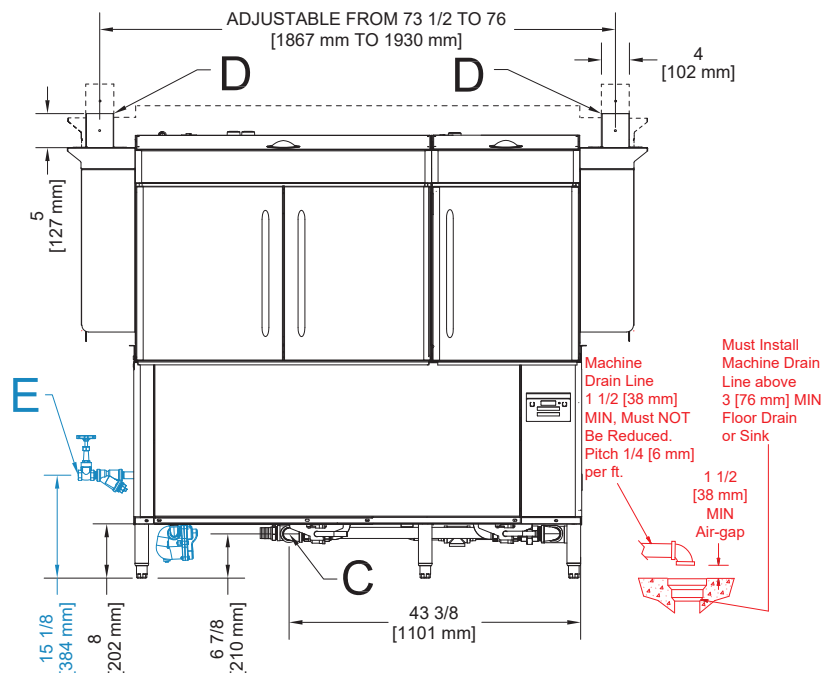
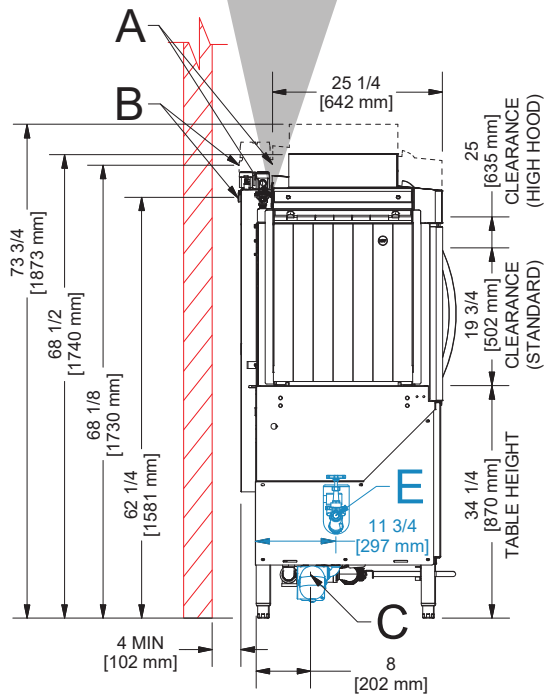
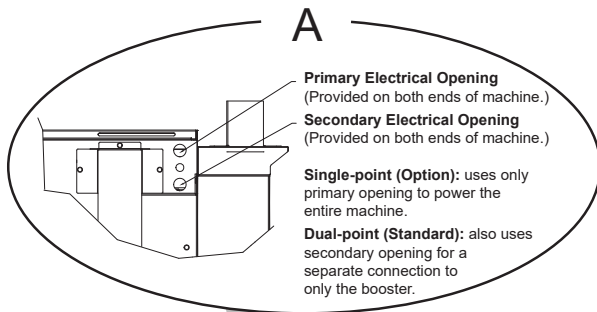
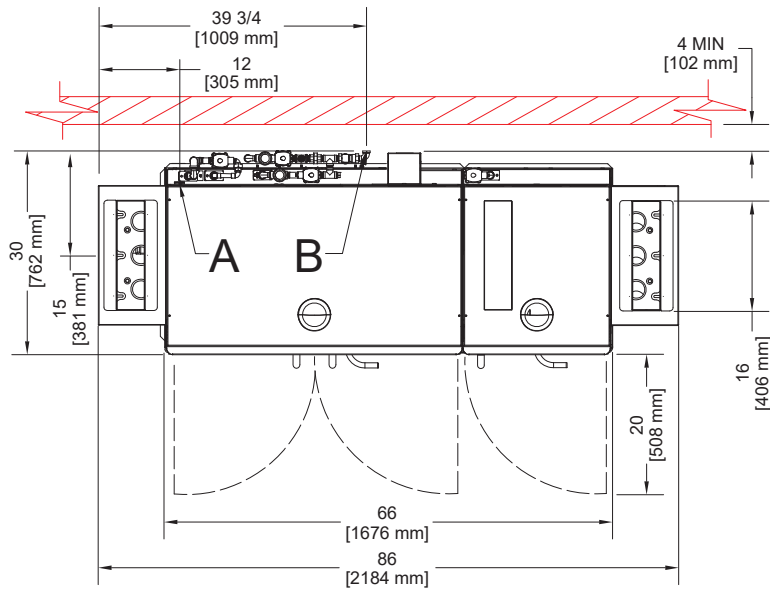

### RECOMMENDED TABLE FABRICATION

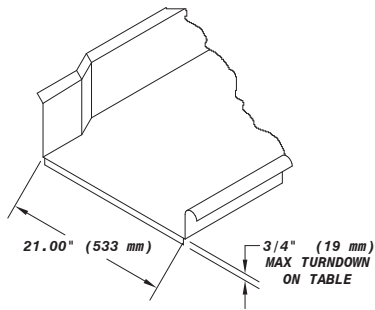

### TABLE CONNECTION

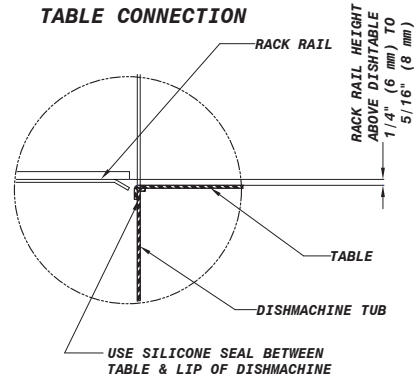

| MODEL NO.                | MACHINE DIMENSIONS   |                           |                 |                       |                    | DRAIN HEIGHT          | SHIPPING INFORMATION |                |                  |                  |                  |  |
|--------------------------|----------------------|---------------------------|-----------------|-----------------------|--------------------|-----------------------|----------------------|----------------|------------------|------------------|------------------|--|
|                          | HEIGHT               | LENGTH BETWEEN DISHTABLES | DEPTH           | DEPTH WITH DOORS OPEN | WEIGHT             |                       | CLASS                | CUBE           | HEIGHT           | WIDTH            | DEPTH            |  |
| RackStar 66              | 68-1/2"<br>(1740 mm) | 66"<br>(1676 mm)          | 30"<br>(762 mm) | 50"<br>(1270 mm)      | 6-7/8"<br>(210 mm) | 1,115 lbs<br>(506 kg) | 150                  | 166.67 cu. ft. | 75"<br>(1905 mm) | 96"<br>(2439 mm) | 40"<br>(1016 mm) |  |
| RackStar 66 Tall Chamber | 73-3/4"<br>(1874 mm) | 66"<br>(1676 mm)          | 30"<br>(762 mm) | 50"<br>(1270 mm)      | 6-7/8"<br>(210 mm) | 1,135 lbs<br>(515 kg) | 150                  | 166.67 cu. ft. | 75"<br>(1905 mm) | 96"<br>(2439 mm) | 40"<br>(1016 mm) |  |

### OPERATING CAPACITY

|                  | High-Temperature | Chemical Sanitizing |
|------------------|------------------|---------------------|
| Racks per Hour   | 223              | 223                 |
| Dishes per Hour  | 5,575            | 5,575               |
| Glasses per Hour | 8,028            | 8,028               |

### OPERATING TEMPERATURES

|                 | High-Temperature          | Chemical Sanitizing       |
|-----------------|---------------------------|---------------------------|
| Pre-Wash        | 110 - 140° F (43 - 60° C) | 110 - 120° F (43 - 49° C) |
| Wash (minimum)  | 160° F (71° C)            | 120° F (49° C)            |
| Rinse (minimum) | 180° F (82° C)            | 120° F (49° C)            |

### ELECTRICAL REQUIREMENTS\*

|            | Power Supply | Total Load | Minimum Circuit Ampacity | Maximum Overcurrent Protection |
|------------|--------------|------------|--------------------------|--------------------------------|
| 70 °F Rise | 208/60/1     | 183.7      | 187.1                    | 200                            |
|            | 230/60/1     | 154.6      | 157.6                    | 165                            |
|            | 208/60/3     | 106.1      | 108.4                    | 115                            |
|            | 230/60/3     | 92.0       | 94.2                     | 100                            |
|            | 460/60/3     | 46.2       | 47.3                     | 50                             |
| 40 °F Rise | 208/60/1     | 154.9      | 158.3                    | 170                            |
|            | 230/60/1     | 130.6      | 133.6                    | 145                            |
|            | 208/60/3     | 91.5       | 93.8                     | 100                            |
|            | 230/60/3     | 78.2       | 80.4                     | 85                             |
|            | 460/60/3     | 39.2       | 40.3                     | 45                             |
| No Booster | 208/60/1     | 97.2       | 100.6                    | 110                            |
|            | 230/60/1     | 82.7       | 85.7                     | 95                             |
|            | 208/60/3     | 58.2       | 60.5                     | 65                             |
|            | 230/60/3     | 50.5       | 52.7                     | 60                             |
|            | 460/60/3     | 25.4       | 26.5                     | 30                             |
| Steam      | 208/60/1     | 25.1       | 28.5                     | 40                             |
|            | 230/60/1     | 22.8       | 25.8                     | 35                             |
|            | 208/60/3     | 16.5       | 18.8                     | 25                             |
|            | 230/60/3     | 15.9       | 18.1                     | 25                             |
|            | 460/60/3     | 8.1        | 9.2                      | 15                             |

### WATER REQUIREMENTS

|  |                                      |
|--|--------------------------------------|
| Inlet Temperature (minimum)                  |                                      |
| With 40° F (22.2° C) Rise Booster Heater     | 140° F (60° C)                       |
| With 70° F (38.9° C) Rise Booster Heater     | 110° F (43° C)                       |
| Gallons per Hour (Econo Rinse / Turbo Rinse) | 78 gal (295 L) / 116 gal (239.1 L)   |
| Gallons per Rack (Econo Rinse / Turbo Rinse) | 0.35 gal (1.3 L) / 0.52 gal (1.97 L) |
| Waterline Size IPS (minimum)                 | 1/2"                                 |
| Drainline Size IPS (minimum)                 | 1-1/2"                               |
| Flow Pressure (PSI)                          | 15                                   |
| Flow Rate GPM (minimum)                      | 1.30 (4.9 LPM)                       |
| Wash Tank Capacity                           | 25 gal (95 L)                        |

### WASH PUMPS

|                        |                    |
|------------------------|--------------------|
| Pre-Wash Pump Motor    | 2 hp               |
| Wash Pump Motor        | 3 hp               |
| Pre-Wash Pump Capacity | 220 GPM (833 LPM)  |
| Wash Pump Capacity     | 270 GPM (1022 LPM) |

### CONVEYOR

|                                  |                     |
|----------------------------------|---------------------|
| Conveyor Motor                   | 1/4 hp              |
| Conveyor Speed (feet per minute) | 6.07 FPM (1.85 MPM) |

### VENTING REQUIREMENTS

|            |         |
|------------|---------|
| Input End  | 200 CFM |
| Output End | 200 CFM |
| Total CFM  | 400 CFM |

### STEAM COIL TANK HEAT (STEAM MODELS ONLY)

|                                |       |
|--------------------------------|-------|
| Steam Connection IPS           | 3/4"  |
| Steam Flow Pressure (PSIG)     | 10-30 |
| Consumption @ 15 PSIG (lbs/hr) | 60    |

HOW TO SPECIFY: RackStar 66

### Jackson WWS, Inc.

Shipping Address: 6209 North U.S. Highway 25E, Gray, KY 40734  
 Mailing Address: P.O. Box 1060, Barbourville, KY 40906  
 Telephone: 888-800-5672 • Fax: 606-523-1799  
 Email: info@jacksonwws.com  
 07610-004-36-87 [03/26/19]

www.jacksonwws.com